

Linear actuators UBA Series and UAL Series

UBA - UAL Series, size 1 - 2 - 3 - 4

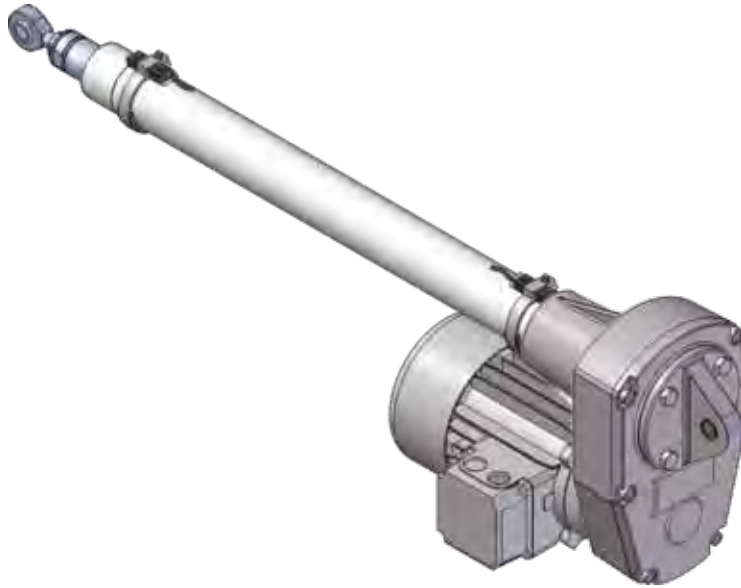

UBA - UAL Series, size 5

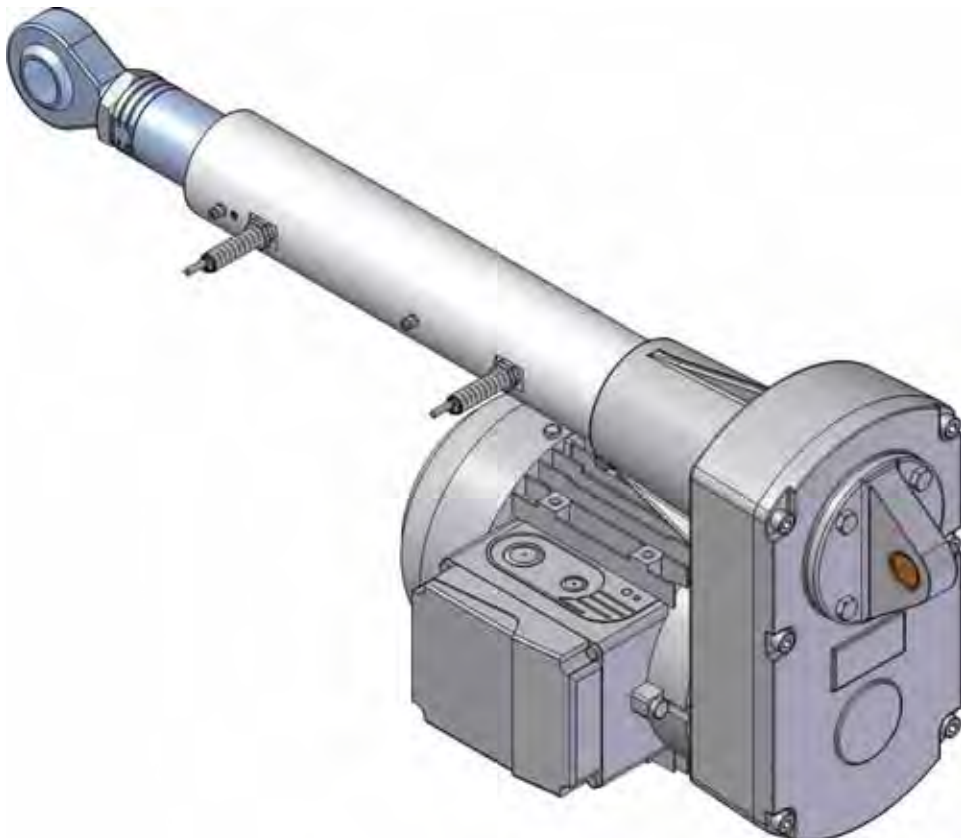

4

Linear actuators UBA Series and UAL Series

4.1 MANUFACTURING FEATURES

Input drive: timing belt transmission; pulleys UNI ISO 5294:1991 in aluminium for low inertia; positive timing belts UNI ISO 5296-1:1991.

Housing: designed and manufactured in monobloc form to obtain a compact body able to sustain heavy axial loads and high machining accuracy. High quality materials are used:

- castings in hardened aluminium alloy EN 1706 AC-AISI10Mg T6

Acme screw:

- ISO trapezoidal thread ISO 2901 ... ISO 2904
- material: steel C 43 (UNI 7847)
- rolled or whirled
- subjected to straightening, to ensure accurate alignment in operation
- max. pitch error ± 0.05 mm over 300 mm length

Bronze nut:

- ISO trapezoidal thread ISO 2901 ... ISO 2904
- material: bronze EN 1982 – CuAl9-C (1-start thread)
- material: bronze EN 1982 – CuSn12-C (multiple start thread)
- max. axial backlash for new nut (0.10 ... 0.12) mm

Outer tube:

- material: aluminium alloy EN AW-6060 thick cold-drawn tube anodized ARC 20 (UNI 4522/66) inner diameter tolerance ISO H9
- steel St 52.2 (DIN 2391) cold-drawn tube inner diameter tolerance ISO H10 ... H11

Bearings:

- on actuator axis: angular contact ball bearings, to avoid axial backlash and to assure high push-pull load capacity

Front attachment:

- standard – with threaded hollow bore, in stainless steel AISI 303 or steel C 43 (UNI 7847)

Rear bracket:

- in aluminium alloy for ATL-BSA 20, 25, 28, 30, 40
- pin in stainless steel AISI 303

Magnetic stroke end switches FCM:

- magnetic switches activated by a magnetic ring, for UAL-UBA 1, 2, 3, 4

Proximity stroke end switches FCP:

- proximity switches activated by the nut, for UAL-UBA 5

Ball screw:

- designed and manufactured by SERVOMECH
- rolled and hardened material: steel 42 CrMo 4 (UNI EN 10083) accuracy grade: ISO IT 7
- hardened and machined material: steel 42 CrMo 4 (UNI EN 10083) accuracy grade: ISO IT 5

Ball nut:

- designed and manufactured by SERVOMECH
- material: steel 18 NiCrMo 5 (UNI EN 10084), case hardened
- max. axial backlash (0.07 ... 0.08) mm
- on request, ball nut with ZERO backlash or pre-loaded using selected diameter balls

Push rod:

- material: steel St 52 (DIN 2391) thick tube chrome-plated, min. chrome thickness 5/100 mm inner diameter tolerance ISO f7
- push rod in stainless steel INOX AISI 304 or special stainless steel on request

Linear actuators UBA Series

4.2 TECHNICAL DATA - ball screw linear actuators UBA Series

SIZE		UBA 1	UBA 2	UBA 3	UBA 4	UBA 5	
Push rod diameter	[mm]	25	30	35	40	50	
Outer tube diameter	[mm]	36	45	55	60	70	
Attachment flange for IEC standard motor		56 B14	63 B14	71 B14	80 B14 90 B14	80 B14 90 B14	
Max. dynamic load.	[N]	1 800	3 400	3 900	5 700	10 850	
Max. static load	pull [N]	4 000	6 000	10 000	12 000	15 000	
	push [N]	4 000	6 000	10 000	12 000	15 000	
Ratio	RV	1 : 1.33 (18 : 24)	1 : 1.4 (20 : 28)	1 : 1.04 (24 : 25)	1 : 1.07 (30 : 32)	1 : 1.07 (30 : 32)	
	RN	1 : 2.15 (13 : 28)	1 : 2.13 (15 : 32)	1 : 2 (16 : 32)	1 : 1.94 (18 : 35)	1 : 1.94 (18 : 35)	
	RL	1 : 3 (10 : 30)	1 : 2.83 (12 : 34)	1 : 2.92 (12 : 35)	1 : 2.93 (15 : 44)	1 : 2.93 (15 : 44)	
Ball screw	Diameter × Lead	14×5	16×5	20×5	25×6	32×10	
	Ball [mm]	3.175 (1/8 ")	3.175 (1/8 ")	3.175 (1/8 ")	3.969 (5/32 ")	6.350 (1/4 ")	
	N° of circuits	2	3	3	3	4	
	Dynamic load C _a [N]	6 600	10 400	12 000	17 400	41 800	
	Static load C _{0a} [N]	8 600	15 600	21 200	30 500	73 000	
Linear travel [mm] for 1 input shaft revolution	Ratio	RV1	3.75	3.57	4.8	5.62	9.38
		RN1	2.32	2.34	2.5	3.09	5.14
		RL1	1.67	1.76	1.71	2.05	3.41
Ball screw	Diameter × Lead	14×10	16×10	20×10	25×10	32×20	
	Ball [mm]	3.175 (1/8 ")	3.175 (1/8 ")	3.175 (1/8 ")	3.969 (5/32 ")	6.350 (1/4 ")	
	N° of circuits	2	3	3	3	3	
	Dynamic load C _a [N]	6 900	11 300	12 900	18 000	32 200	
	Static load C _{0a} [N]	9 300	18 000	23 500	33 000	53 000	
Linear travel [mm] for 1 input shaft revolution	Ratio	RV2	7.5	7.14	9.6	9.38	18.75
		RN2	4.64	4.69	5	5.14	10.29
		RL2	3.33	3.53	3.43	3.41	6.82
Mass (actuator 100 mm stroke length, without motor, with lubricant)	[kg]	3.3	5	8	11	19	
Extra-mass for each additional 100 mm stroke length	[kg]	0.3	0.5	0.8	0.9	2	

Linear actuators UAL Series

4.2 TECHNICAL DATA - acme screw linear actuators UAL Series

SIZE		UAL 1	UAL 2	UAL 3	UAL 4	UAL 5	
Push rod diameter	[mm]	25	30	35	40	50	
Outer tube diameter	[mm]	36	45	55	60	70	
Attachment flange for IEC standard motor		56 B14	63 B14	71 B14	80 B14 90 B14	80 B14 90 B14	
Max. dynamic load	[N]	1 600	2 500	5 100	8 700	10 400	
Max. static load	pull [N]	4 000	6 000	10 000	12 000	15 000	
	push [N]	4 000	6 000	10 000	12 000	15 000	
Ratio	RV	1 : 1.33 (18 : 24)	1 : 1.4 (20 : 28)	1 : 1.04 (24 : 25)	1 : 1.07 (30 : 32)	1 : 1.07 (30 : 32)	
	RN	1 : 2.15 (13 : 28)	1 : 2.13 (15 : 32)	1 : 2 (16 : 32)	1 : 1.94 (18 : 35)	1 : 1.94 (18 : 35)	
	RL	1 : 3 (10 : 30)	1 : 2.83 (12 : 34)	1 : 2.92 (12 : 35)	1 : 2.93 (15 : 44)	1 : 2.93 (15 : 44)	
1-start acme screw		Tr 13.5×3	Tr 16×4	Tr 18×4	Tr 22×5	Tr 30×6	
Linear travel [mm] for 1 input shaft revolution	Ratio	RV1	2.25	2.86	3.84	4.69	5.63
		RN1	1.39	1.88	2	2.57	3.09
		RL1	1	1.41	1.37	1.70	2.05
2-start acme screw		Tr 14×8 (P4)	Tr 16×8 (P4)	Tr 18×8 (P4)	Tr 22×10 (P5)	Tr 30×12 (P6)	
Linear travel [mm] for 1 input shaft revolution	Ratio	RV2	6	5.71	7.68	9.38	11.25
		RN2	3.71	3.75	4	5.14	6.17
		RL2	2.67	2.82	2.74	3.41	4.09
Mass (actuator 100 mm stroke length, without motor, with lubricant)		[kg]	3.3	5	8	11	18
Extra-mass for each additional 100 mm stroke length		[kg]	0.3	0.5	0.8	0.9	2

Linear actuators UBA Series

BALL SCREW LINEAR ACTUATORS UBA Series with AC 3-PHASE MOTOR
PERFORMANCE with: Duty Cycle $F_i = 100\%$ at ambient temperature $25\text{ }^\circ\text{C}$

LINEAR SPEED [mm/s]	DYNAMIC LOAD [N]	RATIO	MOTOR: POWER [kW] – N° of POLES SPEED [rpm]	SELF-LOCKING COEFFICIENT
UBA 1				
350	290 ¹⁾	RV2	0.12 kW 2-pole 2800	0.72
215	460 ¹⁾	RN2	0.12 kW 2-pole 2800	0.72
175	570 ¹⁾	RV1	0.12 kW 2-pole 2800	0.72
155	650 ¹⁾	RL2	0.12 kW 2-pole 2800	0.72
105	950 ¹⁾	RN1	0.12 kW 2-pole 2800	0.72
85	800 ¹⁾	RV1	0.09 kW 4-pole 1400	0.72
75	1300 ¹⁾	RL1	0.12 kW 2-pole 2800	0.72
55	1300 ¹⁾	RN1	0.09 kW 4-pole 1400	0.72
40	1800 ³⁾	RL1	0.09 kW 4-pole 1400	0.72
UBA 2				
330	600 ¹⁾	RV2	0.25 kW 2-pole 2800	0.71
220	900 ¹⁾	RN2	0.25 kW 2-pole 2800	0.71
165	1200 ¹⁾	RL2	0.25 kW 2-pole 2800	0.71
110	1850 ¹⁾	RN1	0.25 kW 2-pole 2800	0.71
80	2450 ¹⁾	RL1	0.25 kW 2-pole 2800	0.71
55	2550 ¹⁾	RN1	0.18 kW 4-pole 1400	0.71
40	3400 ³⁾	RL1	0.18 kW 4-pole 1400	0.71
UBA 3				
450	960 ¹⁾	RV2	0.55 kW 2-pole 2800	0.70
235	1850 ¹⁾	RN2	0.55 kW 2-pole 2800	0.70
160	2700 ¹⁾	RL2	0.55 kW 2-pole 2800	0.70
115	2750 ²⁾	RN1	0.55 kW 2-pole 2800	0.70
80	3550 ¹⁾	RL2	0.37 kW 4-pole 1400	0.70
60	3450 ²⁾	RN1	0.37 kW 4-pole 1400	0.70
40	3900 ²⁾	RL1	0.37 kW 4-pole 1400	0.70
UBA 4				
440	1950 ¹⁾	RV2	1.1 kW 2-pole 2800	0.70
240	3550 ¹⁾	RN2	1.1 kW 2-pole 2800	0.70
160	4700 ²⁾	RL2	1.1 kW 2-pole 2800	0.70
120	4800 ¹⁾	RN2	0.75 kW 4-pole 1400	0.70
96	4500 ²⁾	RL1	1.1 kW 2-pole 2800	0.70
80	5900 ²⁾	RL2	0.75 kW 4-pole 1400	0.70
48	5700 ²⁾	RL1	0.75 kW 4-pole 1400	0.70
UBA 5				
875	1300 ¹⁾	RV2	1.5 kW 2-pole 2800	0.70
480	2400 ¹⁾	RN2	1.5 kW 2-pole 2800	0.70
440	2650 ¹⁾	RV1	1.5 kW 2-pole 2800	0.70
320	3650 ¹⁾	RL2	1.5 kW 2-pole 2800	0.70
240	4800 ¹⁾	RN1	1.5 kW 2-pole 2800	0.70
160	7250 ¹⁾	RL1	1.5 kW 2-pole 2800	0.70
120	7050 ¹⁾	RN1	1.1 kW 4-pole 1400	0.70
80	10650 ¹⁾	RL1	1.1 kW 4-pole 1400	0.70

¹⁾ value limited by electric motor power; ball screw lifetime $L_{10h} > 1000$ hours (see diagrams on pages 33 ... 35)

The total dynamic efficiency (η) of UBA Series actuators, used to determine the DYNAMIC LOAD is calculated as follows:

$$\eta = \eta_1 \times \eta_2 \times \eta_3$$

where:

$\eta_1 = 0.95$ – timing belt transmission efficiency

$\eta_2 = 0.9$ – ball screw - nut efficiency

$\eta_3 = 0.9$ – bearings and sealing elements "efficiency"

²⁾ value related to the ball screw lifetime $L_{10h} = 1000$ h, with constant load, without load vibrations nor shocks; for different lifetime refer to diagrams on pages 33 ... 35

³⁾ limit value of linear actuator dynamic load capacity (see page 128)

Linear actuators UAL Series

ACME SCREW LINEAR ACTUATORS UAL Series with AC 3-PHASE MOTOR
PERFORMANCE with: Duty Cycle $F_i = 30\%$ over 10 min at ambient temperature 25 °C

LINEAR SPEED [mm/s]	DYNAMIC LOAD [N]	RATIO	MOTOR: POWER [kW] – N° of POLES SPEED [rpm]	SELF-LOCKING COEFFICIENT
UAL 1				
280	300 ¹⁾	RV2	0.12 kW 2-pole 2800	0.51
170	450 ¹⁾	RN2	0.12 kW 2-pole 2800	0.51
120	600 ¹⁾	RL2	0.12 kW 2-pole 2800	0.51
105	600 ¹⁾	RV1	0.12 kW 2-pole 2800	0.32
85	600 ¹⁾	RN2	0.09 kW 4-pole 1400	0.51
60	860 ¹⁾	RL2	0.09 kW 4-pole 1400	0.51
50	800 ¹⁾	RV1	0.09 kW 4-pole 1400	0.32
45	1200 ¹⁾	RL1	0.12 kW 2-pole 2800	0.32
32	1200 ¹⁾	RN1	0.09 kW 4-pole 1400	0.32
23	1600 ²⁾	RL1	0.09 kW 4-pole 1400	0.32
UAL 2				
265	650 ¹⁾	RV2	0.25 kW 2-pole 2800	0.48
175	950 ¹⁾	RN2	0.25 kW 2-pole 2800	0.48
130	1200 ¹⁾	RL2	0.25 kW 2-pole 2800	0.48
87	1300 ¹⁾	RN2	0.18 kW 4-pole 1400	0.48
65	1950 ¹⁾	RL1	0.25 kW 2-pole 2800	0.35
43	2000 ¹⁾	RN1	0.18 kW 4-pole 1400	0.35
32	2500 ²⁾	RL1	0.18 kW 4-pole 1400	0.35
UAL 3				
360	1000 ¹⁾	RV2	0.55 kW 2-pole 2800	0.46
180	1850 ¹⁾	RN2	0.55 kW 2-pole 2800	0.46
130	2600 ¹⁾	RL2	0.55 kW 2-pole 2800	0.46
90	3000 ¹⁾	RN1	0.55 kW 2-pole 2800	0.32
64	4100 ¹⁾	RL1	0.55 kW 2-pole 2800	0.32
46	3650 ¹⁾	RN1	0.37 kW 4-pole 1400	0.32
32	5100 ²⁾	RL1	0.37 kW 4-pole 1400	0.32
UAL 4				
440	1700 ¹⁾	RV2	1.1 kW 2-pole 2800	0.46
240	3000 ¹⁾	RN2	1.1 kW 2-pole 2800	0.46
160	4300 ¹⁾	RL2	1.1 kW 2-pole 2800	0.46
120	5000 ¹⁾	RN1	1.1 kW 2-pole 2800	0.32
80	7000 ¹⁾	RL1	1.1 kW 2-pole 2800	0.32
60	6200 ¹⁾	RN1	0.75 kW 4-pole 1400	0.32
40	8700 ²⁾	RL1	0.75 kW 4-pole 1400	0.32
UAL 5				
529	2000 ¹⁾	RV2	1.5 kW 2-pole 2800	0.44
292	3350 ¹⁾	RN2	1.5 kW 2-pole 2800	0.44
265	3350 ¹⁾	RV1	1.5 kW 2-pole 2800	0.30
193	4800 ¹⁾	RL2	1.5 kW 2-pole 2800	0.44
146	5500 ¹⁾	RN1	1.5 kW 2-pole 2800	0.30
97	7800 ¹⁾	RL1	1.5 kW 2-pole 2800	0.30
72	7300 ¹⁾	RN1	1.1 kW 4-pole 1400	0.30
48	10400 ²⁾	RL1	1.1 kW 4-pole 1400	0.30

1) value limited by electric motor power

The total dynamic efficiency (η) of UAL Series actuators, used to determine the DYNAMIC LOAD is calculated as follows:

$$\eta = \eta_1 \times \eta_2 \times \eta_3$$

where:

$\eta_1 = 0.95$ – timing belt transmission efficiency

η_2 – acme screw-bronze nut dynamic efficiency, calculated with reference to the speed

$\eta_3 = 0.9$ – bearings and sealing elements "efficiency"

2) limit value of linear actuator dynamic load capacity (see page 129)

Linear actuators UBA Series

BALL SCREW LINEAR ACTUATORS UBA Series with AC 1-PHASE MOTOR
PERFORMANCE with: Duty Cycle $F_i = 100\%$ at ambient temperature $25\text{ }^\circ\text{C}$

LINEAR SPEED [mm/s]	DYNAMIC LOAD [N]	RATIO	MOTOR: POWER [kW] – N° of POLES SPEED [rpm]	SELF-LOCKING COEFFICIENT
UBA 1				
350	250 ¹⁾	RV2	0.12 kW 2-pole 2800	0.72
215	400 ¹⁾	RN2	0.12 kW 2-pole 2800	0.72
175	500 ¹⁾	RV1	0.12 kW 2-pole 2800	0.72
155	600 ¹⁾	RL2	0.12 kW 2-pole 2800	0.72
105	850 ¹⁾	RN1	0.12 kW 2-pole 2800	0.72
85	750 ¹⁾	RV1	0.09 kW 4-pole 1400	0.72
75	1200 ¹⁾	RL1	0.12 kW 2-pole 2800	0.72
55	1300 ¹⁾	RN1	0.09 kW 4-pole 1400	0.72
40	1800 ³⁾	RL1	0.09 kW 4-pole 1400	0.72
UBA 2				
330	550 ¹⁾	RV2	0.25 kW 2-pole 2800	0.71
220	850 ¹⁾	RN2	0.25 kW 2-pole 2800	0.71
165	1100 ¹⁾	RL2	0.25 kW 2-pole 2800	0.71
110	1650 ¹⁾	RN1	0.25 kW 2-pole 2800	0.71
80	2300 ¹⁾	RL1	0.25 kW 2-pole 2800	0.71
55	2550 ¹⁾	RN1	0.18 kW 4-pole 1400	0.71
40	3400 ³⁾	RL1	0.18 kW 4-pole 1400	0.71
UBA 3				
450	960 ¹⁾	RV2	0.55 kW 2-pole 2800	0.70
235	1850 ¹⁾	RN2	0.55 kW 2-pole 2800	0.70
160	2700 ¹⁾	RL2	0.55 kW 2-pole 2800	0.70
115	2750 ²⁾	RN1	0.55 kW 2-pole 2800	0.70
80	3550 ¹⁾	RL2	0.37 kW 4-pole 1400	0.70
60	3450 ²⁾	RN1	0.37 kW 4-pole 1400	0.70
40	3900 ²⁾	RL1	0.37 kW 4-pole 1400	0.70
UBA 4				
440	1900 ¹⁾	RV2	1.1 kW 2-pole 2800	0.70
240	3500 ¹⁾	RN2	1.1 kW 2-pole 2800	0.70
160	4700 ²⁾	RL2	1.1 kW 2-pole 2800	0.70
120	4800 ¹⁾	RN2	0.75 kW 4-pole 1400	0.70
96	4500 ²⁾	RL1	1.1 kW 2-pole 2800	0.70
80	5900 ²⁾	RL2	0.75 kW 4-pole 1400	0.70
48	5700 ²⁾	RL1	0.75 kW 4-pole 1400	0.70

¹⁾ value limited by electric motor power; ball screw lifetime $L_{10h} > 1000$ hours (see diagrams on pages 33 ... 35)

The total dynamic efficiency (η) of UBA Series actuators, used to determine the DYNAMIC LOAD is calculated as follows:

$$\eta = \eta_1 \times \eta_2 \times \eta_3$$

where:

$\eta_1 = 0.95$ – timing belt transmission efficiency

$\eta_2 = 0.9$ – ball screw - nut efficiency

$\eta_3 = 0.9$ – bearings and sealing elements "efficiency"

²⁾ value related to the ball screw lifetime $L_{10h} = 1000$ h, with constant load, without load vibrations nor shocks; for different lifetime refer to diagrams on pages 33 ... 35

³⁾ limit value of linear actuator dynamic load capacity (see page 128)

Linear actuators UAL Series

ACME SCREW LINEAR ACTUATORS UAL Series with AC 1-PHASE MOTOR
PERFORMANCE with: Duty Cycle $F_i = 30\%$ over 10 min at ambient temperature 25 °C

LINEAR SPEED [mm/s]	DYNAMIC LOAD [N]	RATIO	MOTOR: POWER [kW] – N° of POLES SPEED [rpm]	SELF-LOCKING COEFFICIENT
UAL 1				
280	300 ¹⁾	RV2	0.12 kW 2-pole 2800	0.51
170	450 ¹⁾	RN2	0.12 kW 2-pole 2800	0.51
120	600 ¹⁾	RL2	0.12 kW 2-pole 2800	0.51
105	600 ¹⁾	RV1	0.12 kW 2-pole 2800	0.32
85	600 ¹⁾	RN2	0.09 kW 4-pole 1400	0.51
60	860 ¹⁾	RL2	0.09 kW 4-pole 1400	0.51
50	800 ¹⁾	RV1	0.09 kW 4-pole 1400	0.32
45	1200 ¹⁾	RL1	0.12 kW 2-pole 2800	0.32
32	1200 ¹⁾	RN1	0.09 kW 4-pole 1400	0.32
23	1600 ²⁾	RL1	0.09 kW 4-pole 1400	0.32
UAL 2				
265	600 ¹⁾	RV2	0.25 kW 2-pole 2800	0.48
175	850 ¹⁾	RN2	0.25 kW 2-pole 2800	0.48
130	1100 ¹⁾	RL2	0.25 kW 2-pole 2800	0.48
87	1200 ¹⁾	RN2	0.18 kW 4-pole 1400	0.48
65	1800 ¹⁾	RL1	0.25 kW 2-pole 2800	0.35
43	2000 ¹⁾	RN1	0.18 kW 4-pole 1400	0.35
32	2500 ²⁾	RL1	0.18 kW 4-pole 1400	0.35
UAL 3				
360	900 ¹⁾	RV2	0.55 kW 2-pole 2800	0.46
180	1650 ¹⁾	RN2	0.55 kW 2-pole 2800	0.46
130	2350 ¹⁾	RL2	0.55 kW 2-pole 2800	0.46
90	2700 ¹⁾	RN1	0.55 kW 2-pole 2800	0.32
64	3700 ¹⁾	RL1	0.55 kW 2-pole 2800	0.32
46	3300 ¹⁾	RN1	0.37 kW 4-pole 1400	0.32
32	4600 ¹⁾	RL1	0.37 kW 4-pole 1400	0.32
UAL 4				
440	1550 ¹⁾	RV2	1.1 kW 2-pole 2800	0.46
240	2700 ¹⁾	RN2	1.1 kW 2-pole 2800	0.46
160	3900 ¹⁾	RL2	1.1 kW 2-pole 2800	0.46
120	4500 ¹⁾	RN1	1.1 kW 2-pole 2800	0.32
80	6300 ¹⁾	RL1	1.1 kW 2-pole 2800	0.32
60	5600 ¹⁾	RN1	0.75 kW 4-pole 1400	0.32
40	7900 ¹⁾	RL1	0.75 kW 4-pole 1400	0.32

1) value limited by electric motor power

The total dynamic efficiency (η) of UAL Series actuators, used to determine the DYNAMIC LOAD is calculated as follows:

$$\eta = \eta_1 \times \eta_2 \times \eta_3$$

where:

$\eta_1 = 0.95$ – timing belt transmission efficiency

η_2 – acme screw-bronze nut dynamic efficiency, calculated with reference to the speed

$\eta_3 = 0.9$ – bearings and sealing elements "efficiency"

2) limit value of linear actuator dynamic load capacity (see page 129)

Linear actuators UBA Series

BALL SCREW LINEAR ACTUATORS UBA Series with DC MOTOR
PERFORMANCE with: Duty Cycle $F_i = 100\%$ at ambient temperature $25\text{ }^\circ\text{C}$

LINEAR SPEED [mm/s]	DYNAMIC LOAD [N]	RATIO	MOTOR: POWER [kW] – N° of POLES SPEED [rpm]	SELF-LOCKING COEFFICIENT
UBA 1 with DC motor 24 V 3000 rpm 150 W 8.4 A				
375	300 ¹⁾	RV2	9	0.72
230	500 ¹⁾	RN2	9	0.72
165	700 ¹⁾	RL2	9	0.72
115	1000 ¹⁾	RN1	9	0.72
85	1400 ¹⁾	RL1	9	0.72
UBA 2 with DC motor 24 V 3000 rpm 300 W 15.6 A				
360	650 ¹⁾	RV2	16	0.71
235	1000 ¹⁾	RN2	16	0.71
175	1300 ¹⁾	RL2	16	0.71
120	2000 ¹⁾	RN1	16	0.71
90	2600 ²⁾	RL1	16	0.71
UBA 3 with DC motor 24 V 3000 rpm 500 W 25 A				
480	800 ¹⁾	RV2	26	0.70
240	1600 ¹⁾	RV1	26	0.70
170	2250 ¹⁾	RL2	26	0.70
125	2700 ²⁾	RN1	22	0.70
85	3050 ²⁾	RL1	17.5 (*)	0.70
* - performances with DC motor 24 V 3000 rpm 300 W				
UBA 4 with DC motor 90 V 3000 rpm 750 W 10.6 A				
470	1250 ¹⁾	RV2	11	0.70
260	2250 ¹⁾	RN2	11	0.70
155	3750 ¹⁾	RN1	11	0.70
100	4400 ²⁾	RL1	8.5	0.70

1) value limited by electric motor power; ball screw lifetime $L_{10h} > 1000$ hours (see diagrams on pages 33 ... 35)

The total dynamic efficiency (η) of UBA Series actuators, used to determine the DYNAMIC LOAD is calculated as follows:

$$\eta = \eta_1 \times \eta_2 \times \eta_3$$

where:

$\eta_1 = 0.95$ – timing belt transmission efficiency

$\eta_2 = 0.9$ – ball screw - nut efficiency

$\eta_3 = 0.9$ – bearings and sealing elements "efficiency"

2) value related to the ball screw lifetime $L_{10h} = 1000$ h, with constant load, without load vibrations nor shocks; for different lifetime refer to diagrams on pages 33 ... 35

3) limit value of linear actuator dynamic load capacity (see page 128)

Linear actuators UAL Series

ACME SCREW LINEAR ACTUATORS UAL Series with DC MOTOR
PERFORMANCE with: Duty Cycle $F_i = 30\%$ over 10 min at ambient temperature 25 °C

LINEAR SPEED [mm/s]	DYNAMIC LOAD [N]	RATIO	MOTOR: POWER [kW] – N° of POLES SPEED [rpm]	SELF-LOCKING COEFFICIENT
UAL 1 with DC motor 24 V 3000 rpm 150 W 8.4 A				
300	350 ¹⁾	RV2	9	0.51
185	500 ¹⁾	RN2	9	0.51
130	700 ¹⁾	RL2	9	0.51
112	700 ¹⁾	RV1	9	0.32
70	1000 ¹⁾	RN1	9	0.32
50	1400 ¹⁾	RL1	9	0.32
UAL 2 with DC motor 24 V 3000 rpm 300 W 15.6 A				
285	700 ¹⁾	RV2	16	0.48
185	1050 ¹⁾	RN2	16	0.48
140	1350 ¹⁾	RL2	16	0.48
93	1700 ¹⁾	RN1	16	0.35
70	2200 ¹⁾	RL1	16	0.35
UAL 3 with DC motor 24 V 3000 rpm 500 W 25 A				
384	900 ¹⁾	RV2	26	0.46
200	1600 ¹⁾	RN2	26	0.46
137	2300 ¹⁾	RL2	26	0.46
100	2600 ¹⁾	RN1	26	0.32
68	3600 ¹⁾	RL1	26	0.32
UAL 4 with DC motor 90 V 3000 rpm 750 W 10.6 A				
470	1100 ¹⁾	RV2	11	0.46
250	2000 ¹⁾	RN2	12	0.46
170	2750 ¹⁾	RL2	11	0.46
125	3150 ¹⁾	RN1	11	0.32
85	4500 ¹⁾	RL1	11	0.32

1) value limited by electric motor power

The total dynamic efficiency (η) of UAL Series actuators, used to determine the DYNAMIC LOAD is calculated as follows:

$$\eta = \eta_1 \times \eta_2 \times \eta_3$$

where:

$\eta_1 = 0.95$ – timing belt transmission efficiency

η_2 – acme screw-bronze nut dynamic efficiency, calculated with reference to the speed

$\eta_3 = 0.9$ – bearings and sealing elements "efficiency"

2) limit value of linear actuator dynamic load capacity (see page 129)

Linear actuators UBA Series

BALL SCREW LINEAR ACTUATORS UBA Series, size 1 – 2 – 3 – 4
 AC 3-phase or 1-phase MOTOR – with Magnetic Stroke Limit Switches FCM

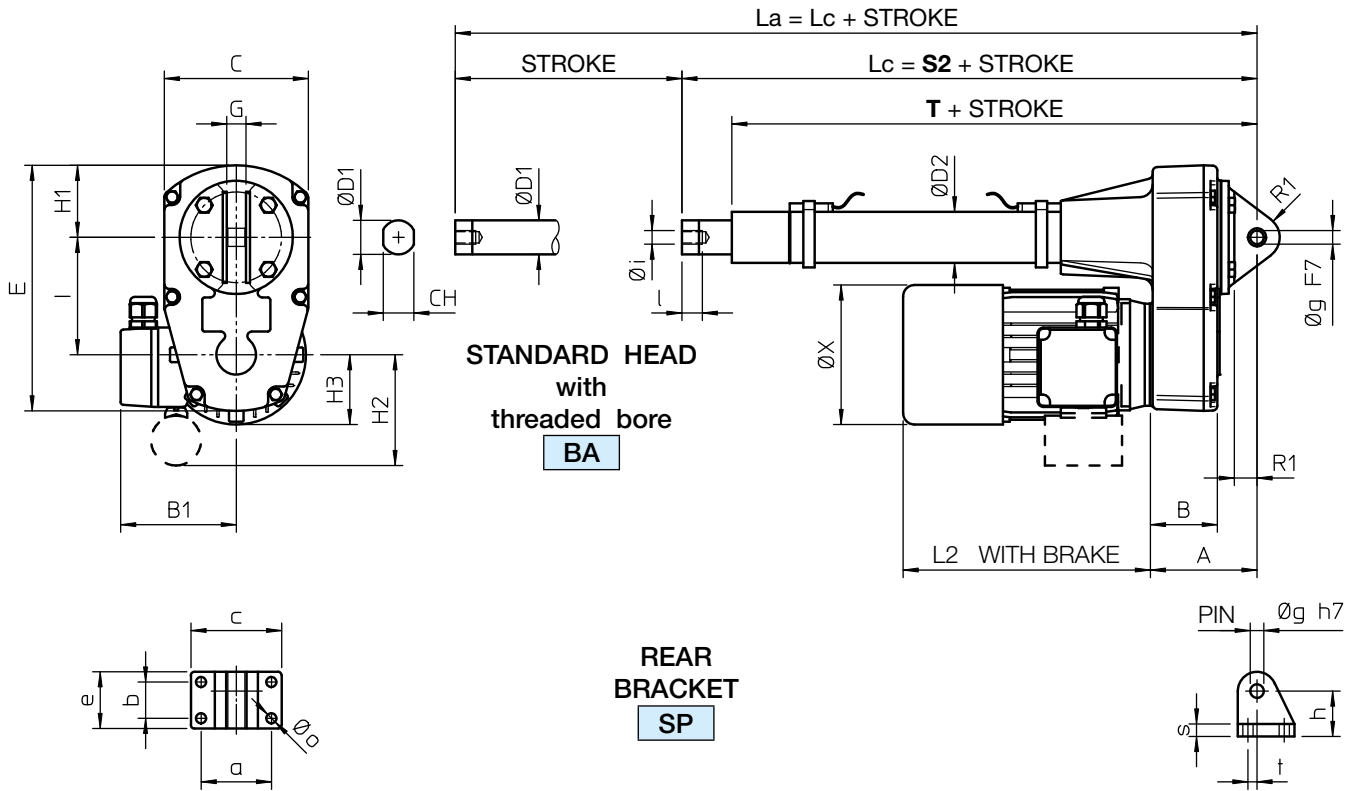

Lc - RETRACTED ACTUATOR length
 La - EXTENDED ACTUATOR length

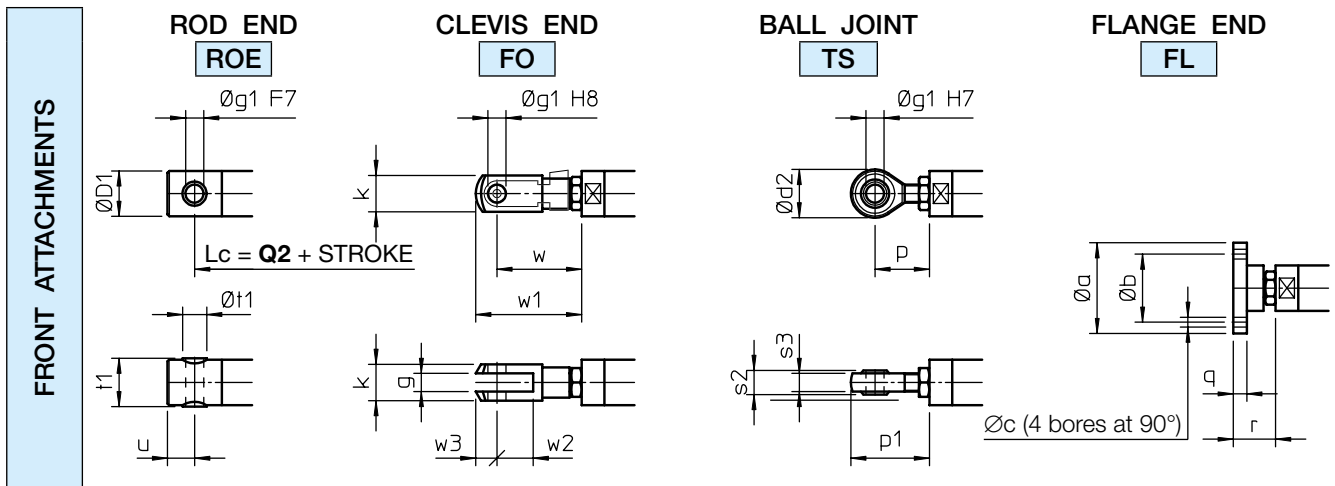

MAGNETIC STROKE LIMIT SWITCHES FCM Dimensions

	L	
	REED CONTACT NC or (NC+NO)	NO
UBA 1	42	47
UBA 2	51	56
UBA 3	59	64
UBA 4	69	74

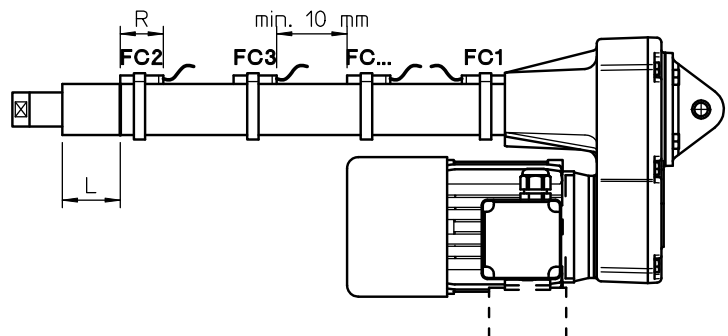

Linear actuators UBA Series

BALL SCREW LINEAR ACTUATORS UBA Series, size 1 – 2 – 3 – 4
AC 3-phase or 1-phase MOTOR – with Magnetic Stroke Limit Switches FCM
STANDARD STROKE LENGTHS

		STROKE CODE	C100	C200	C300	C400	C500	C600	C700	C800	S2	T	Q2
UBA 1	R_1	STROKE [mm]	100	200	300	400	500	600	700	800	287	250	287
	R_2										303	266	303
UBA 2	R_1										307	263	310
	R_2										330	286	333
UBA 3	R_1										342	296	348
	R_2										367	321	373
UBA 4	R_1										406	352	418
	R_2										419	365	431

NOTE: Different stroke lengths available on request. $L_a = L_c + \text{STROKE}$

For stroke lengths longer than 800 mm it is necessary to increase the guided length between push rod and outer tube to avoid axial backlash. Dimensions **S2**, **T** and **Q2** shall be considered increased by 200 mm for stroke lengths up to 1500 mm.

For stroke lengths longer than 1500 mm, please, contact SERVOMECH.

	A	B	B1	C	CH	∅ D1	∅ D2	E	G	H1	H2	H3	I	L2
UBA 1	85	52	110	114	22	25	36	189	15	58	75	55	90	193
UBA 2	94	60	115	127	27	30	45	217	17	64	90	62	104	229
UBA 3	106	71	124	135	30	35	55	247	20	68	90	75	121	304
UBA 4	120	77	141	161	36	40	60	293	24	81	95	90	138	340

	R1	∅ X	a	b	c	e	∅ g	h	∅ i	l	∅ o	r1	s	t
UBA 1	17	110	54	28	73	46	10	36	M10×1.5	17	9	18	10	4
UBA 2	20	123	62	32	80	50	12	40	M12×1.75	18	9	20	11	8
UBA 3	20	150	72	38	90	58	14	45	M14×2	24	9	22	12	8
UBA 4	22	170	85	55	110	81	20	58	M20×1.5	27	11	29	15	15

4

FRONT ATTACHMENT Dimensions

	∅ a	∅ b	∅ c	∅ D1	∅ d2	g	∅ g1	k	p	p1
UBA 1	55	40	5.5	25	28	10	10	20	31	45
UBA 2	60	45	6.5	30	32	12	12	24	36	52
UBA 3	65	50	6.5	35	36	14	14	27	36	54
UBA 4	80	60	8.5	40	50	20	20	40	53	78

	q	r	s2	s3	t1	∅ t1	u	w	w1	w2	w3
UBA 1	8	27	14	11	26	14	15	49	61	20	12
UBA 2	9	28	16	12	32	16	18	56	70	24	14
UBA 3	9	32	19	14	36	18	21	65	81	28	16
UBA 4	10	42	25	18	42	25	27	90	115	40	25

MAGNETIC STROKE LIMIT SWITCHES FCM Technical features and dimensions

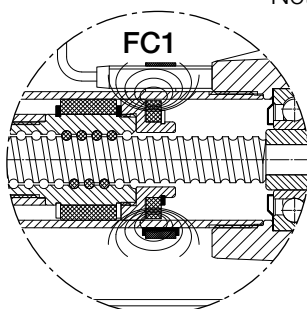

Note: - Additional extra magnetic REED SWITCHES are available for intermediate positions.

- The minimum distance between the REED SWITCHES must be of at least 10 mm.

- REED SWITCH Normally Closed (NC) R = 39 mm

- REED SWITCH Change-over (NC+NO) R = 39 mm

- REED SWITCH Normally Open (NO) R = 29 mm

Linear actuators UBA Series

BALL SCREW LINEAR ACTUATORS UBA Series, size 1 – 2 – 3 – 4
DC MOTOR – with Magnetic Stroke Limit Switches FCM

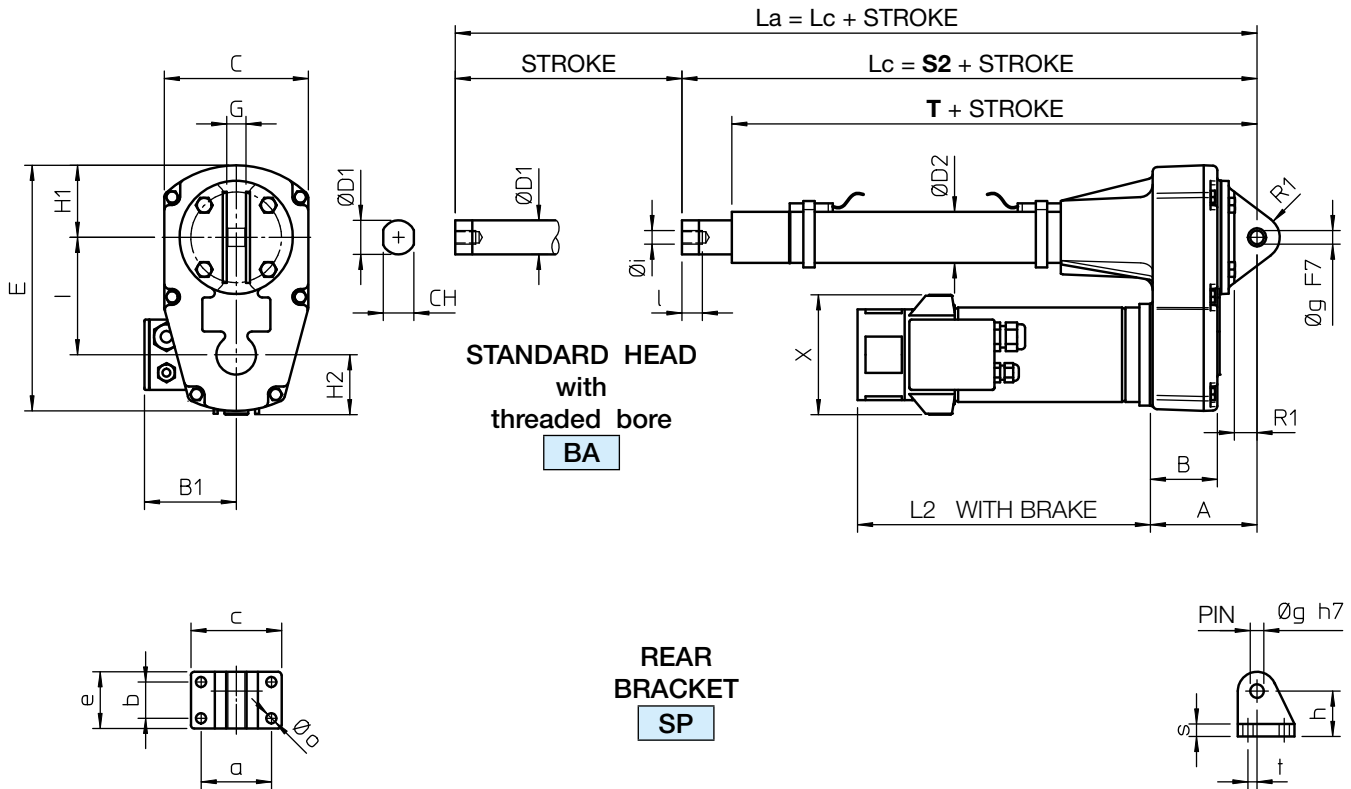

Lc - RETRACTED ACTUATOR length
La - EXTENDED ACTUATOR length

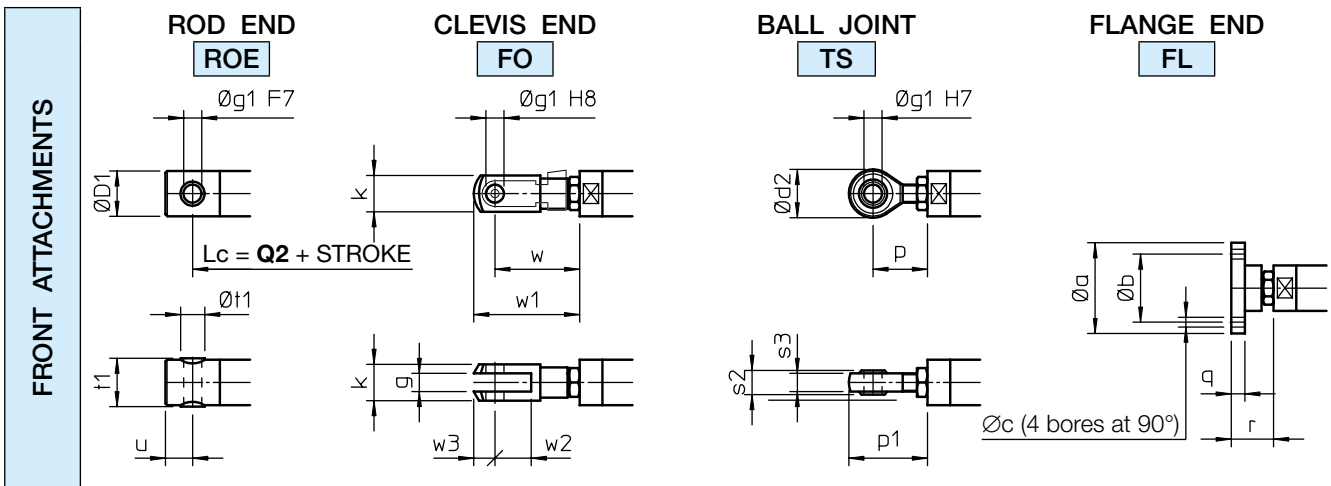

MAGNETIC STROKE LIMIT SWITCHES FCM Dimensions

	L	
	REED CONTACT NC or (NC+NO)	NO
UBA 1	42	47
UBA 2	51	56
UBA 3	59	64
UBA 4	69	74

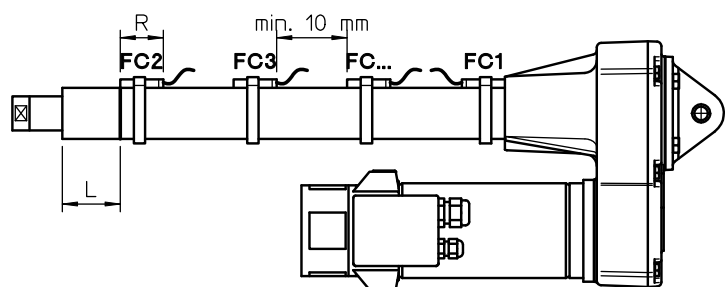

Linear actuators UBA Series

BALL SCREW LINEAR ACTUATORS UBA Series, size 1 – 2 – 3 – 4
DC MOTOR – with Magnetic Stroke Limit Switches FCM
STANDARD STROKE LENGTHS

		STROKE CODE	C100	C200	C300	C400	C500	C600	C700	C800	S2	T	Q2
UBA 1	R_1	STROKE [mm]	100	200	300	400	500	600	700	800	287	250	287
	R_2										303	266	303
UBA 2	R_1										307	263	310
	R_2										330	286	333
UBA 3	R_1										342	296	348
	R_2										367	321	373
UBA 4	R_1										406	352	418
	R_2										419	365	431

NOTE: Different stroke lengths available on request. $L_a = L_c + \text{STROKE}$

For stroke lengths longer than 800 mm it is necessary to increase the guided length between push rod and outer tube to avoid axial backlash. Dimensions **S2**, **T** and **Q2** shall be considered increased by 200 mm for stroke lengths up to 1500 mm.

For stroke lengths longer than 1500 mm, please, contact SERVOMECH.

	A	B	B1	C	CH	∅ D1	∅ D2	E	G	H1	H2	H3	I	L2
UBA 1	85	52	80	114	22	25	36	189	15	58	75	55	90	193
UBA 2	94	60	80	127	27	30	45	217	17	64	90	62	104	229
UBA 3	106	71	80	135	30	35	55	247	20	68	90	75	121	304
UBA 4	120	77	118	161	36	40	60	293	24	81	95	90	138	340

	R1	X	a	b	c	e	∅ g	h	∅ i	l	∅ o	r1	s	t
UBA 1	17	107	54	28	73	46	10	36	M10×1.5	17	9	18	10	4
UBA 2	20	107	62	32	80	50	12	40	M12×1.75	18	9	20	11	8
UBA 3	20	107	72	38	90	58	14	45	M14×2	24	9	22	12	8
UBA 4	22	138	85	55	110	81	20	58	M20×1.5	27	11	29	15	15

4

FRONT ATTACHMENT Dimensions

	∅ a	∅ b	∅ c	∅ D1	∅ d2	g	∅ g1	k	p	p1
UBA 1	55	40	5.5	25	28	10	10	20	31	45
UBA 2	60	45	6.5	30	32	12	12	24	36	52
UBA 3	65	50	6.5	35	36	14	14	27	36	54
UBA 4	80	60	8.5	40	50	20	20	40	53	78

	q	r	s2	s3	t1	∅ t1	u	w	w1	w2	w3
UBA 1	8	27	14	11	26	14	15	49	61	20	12
UBA 2	9	28	16	12	32	16	18	56	70	24	14
UBA 3	9	32	19	14	36	18	21	65	81	28	16
UBA 4	10	42	25	18	42	25	27	90	115	40	25

MAGNETIC STROKE LIMIT SWITCHES FCM Technical features and dimensions

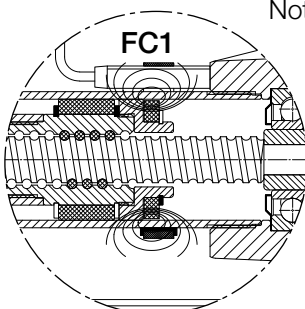

- Note: - Additional extra magnetic REED SWITCHES are available for intermediate positions.
 - The minimum distance between the REED SWITCHES must be of at least 10 mm.
- | | | | |
|---------------|-----------------|---------|-----------|
| - REED SWITCH | Normally Closed | (NC) | R = 39 mm |
| - REED SWITCH | Change-over | (NC+NO) | R = 39 mm |
| - REED SWITCH | Normally Open | (NO) | R = 29 mm |

Linear actuators UBA Series

BALL SCREW LINEAR ACTUATOR UBA 5 AC 3-phase MOTOR — with Proximity Stroke Limit Switches FCP

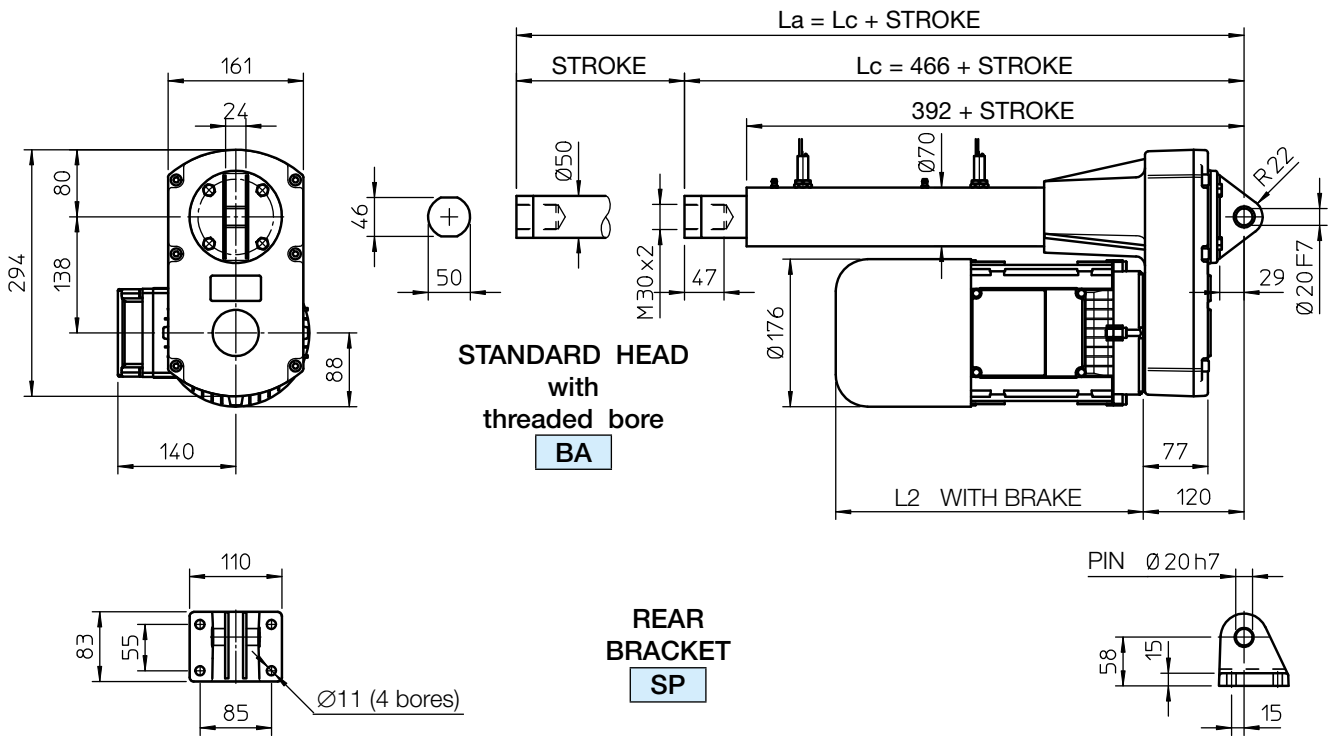

L_c - RETRACTED ACTUATOR length
 L_a - EXTENDED ACTUATOR length

NOTE: The STROKE that the actuator can perform corresponds to the STROKE CODE of the ordering code (STROKE CODE C100 means STROKE = 100 mm)
 For stroke lengths longer than 800 mm it is necessary to increase the guided length between push rod and outer tube to avoid axial backlash. The length L_c shall be considered increased by 200 mm for stroke lengths up to 1500 mm.
 For stroke lengths longer than 1500 mm please contact SERVOMECH.

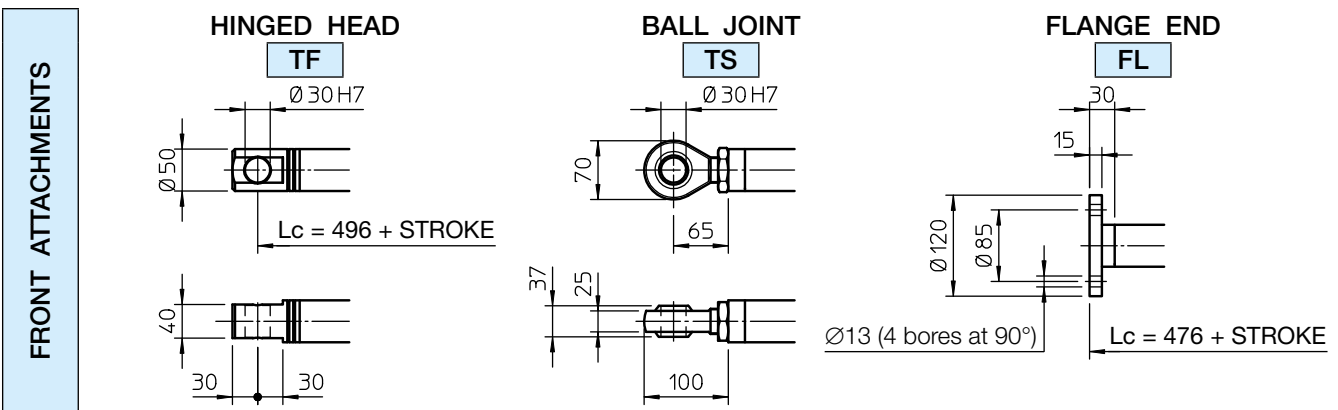

Linear actuators UAL Series

ACME SCREW LINEAR ACTUATOR UAL 5 AC 3-phase MOTOR – with Proximity Stroke Limit Switches FCP

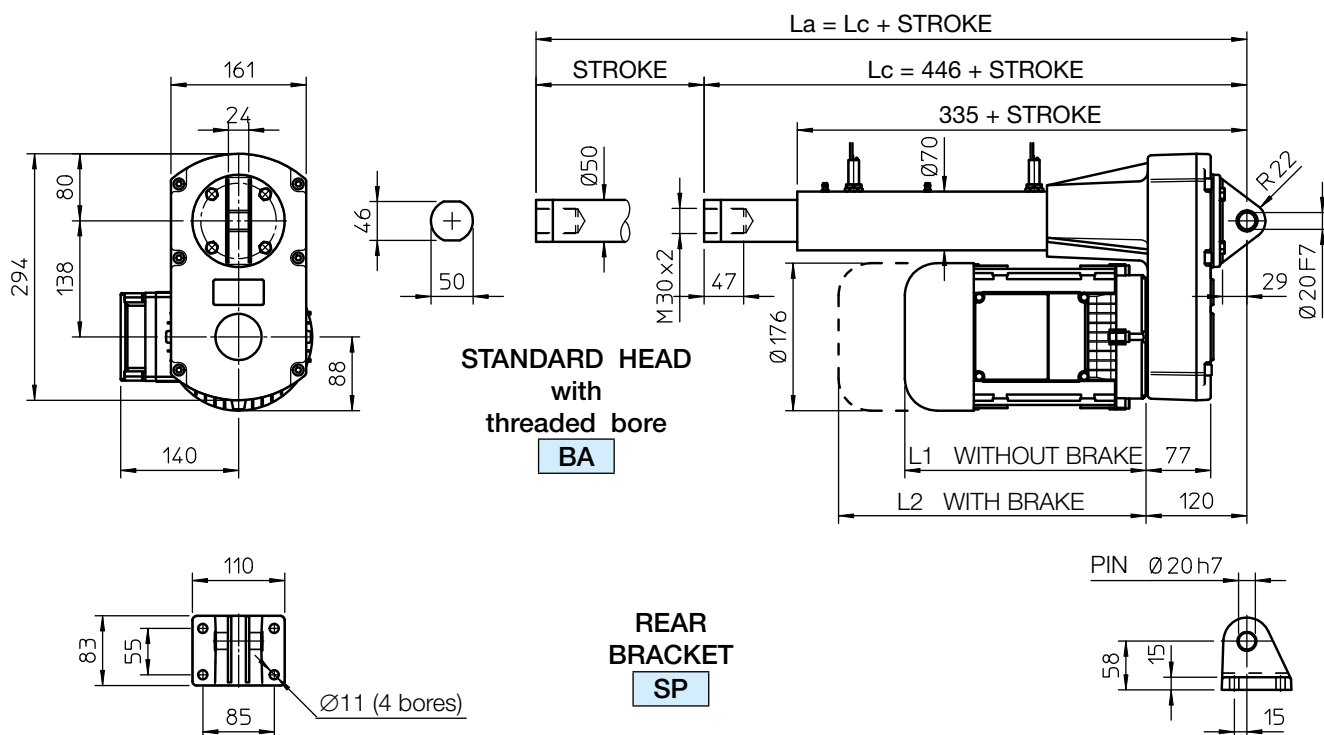

Lc - RETRACTED ACTUATOR length
La - EXTENDED ACTUATOR length

NOTE: The STROKE that the actuator can perform corresponds to the STROKE CODE of the ordering code (STROKE CODE C100 means STROKE = 100 mm)

For stroke lengths longer than 800 mm it is necessary to increase the guided length between push rod and outer tube to avoid axial backlash. The length Lc shall be considered increased by 200 mm for stroke lengths up to 1500 mm.

For stroke lengths longer than 1500 mm please contact SERVOMECH.

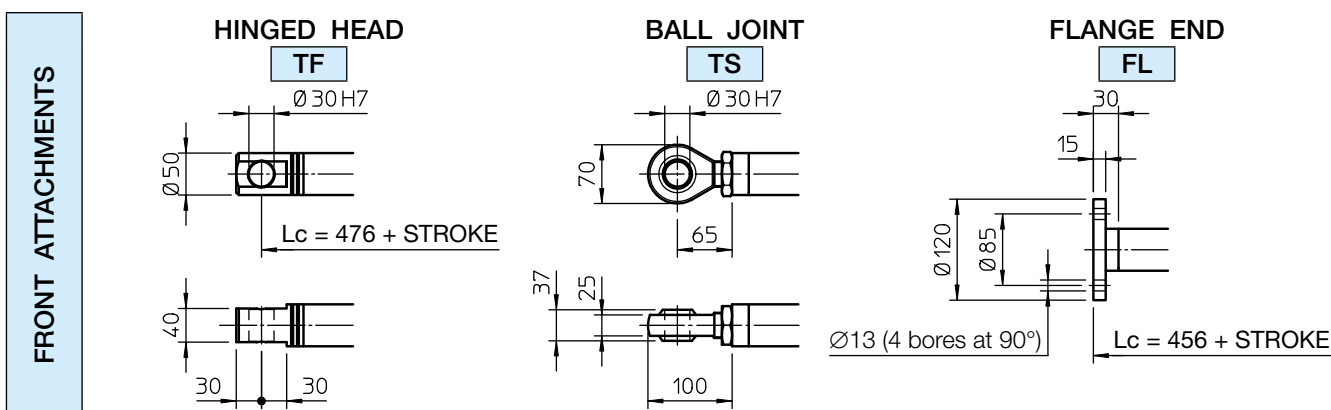

Linear actuators UAL Series

ACME SCREW LINEAR ACTUATORS UAL Series, size 1 – 2 – 3 – 4
 AC 3-phase or 1-phase MOTOR – with Magnetic Stroke Limit Switches FCM

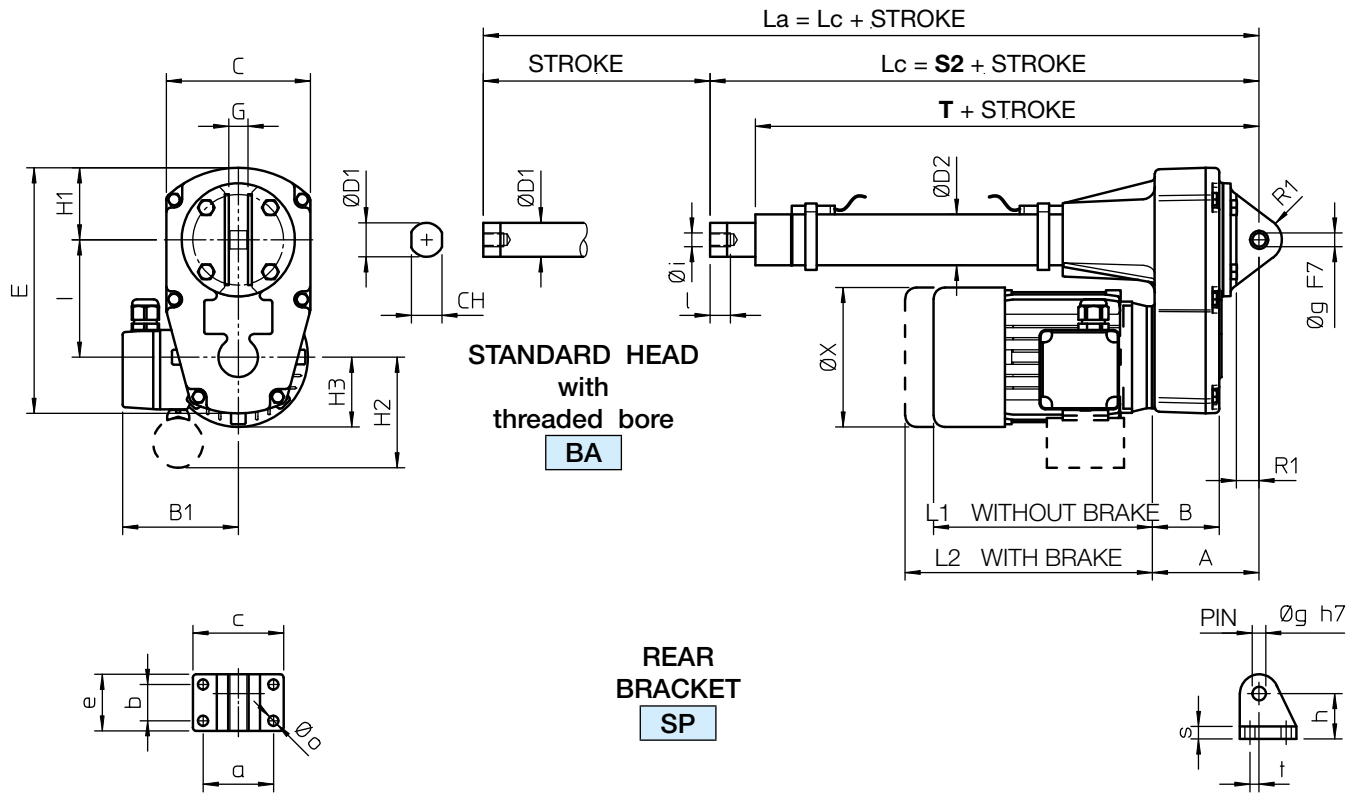

Lc - RETRACTED ACTUATOR length
 La - EXTENDED ACTUATOR length

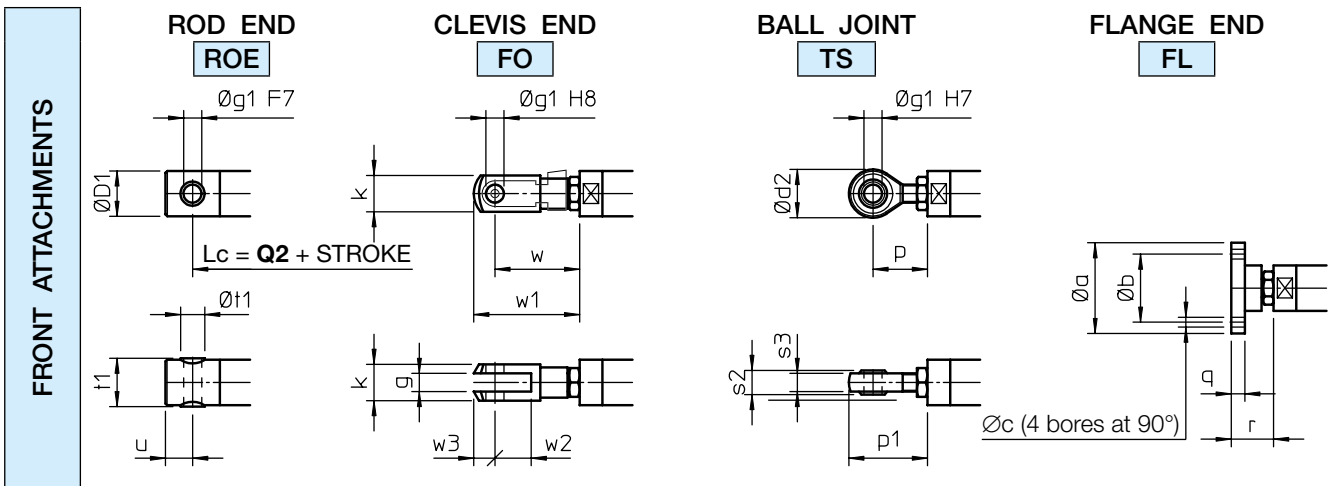

MAGNETIC STROKE LIMIT SWITCHES FCM Dimensions

	L	
	REED CONTACT NC or (NC+NO)	NO
UAL 1	42	47
UAL 2	51	56
UAL 3	59	64
UAL 4	69	74

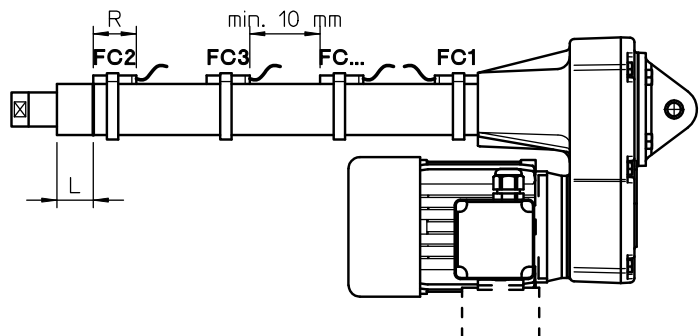

Linear actuators UAL Series

ACME SCREW LINEAR ACTUATORS UAL Series, size 1 – 2 – 3 – 4
AC 3-phase or 1-phase MOTOR – with Magnetic Stroke Limit Switches FCM
STANDARD STROKE LENGTHS

	STROKE CODE	C100	C200	C300	C400	C500	C600	C700	C800	S2	T	Q2
UAL 1	STROKE [mm]	100	200	300	400	500	600	700	800	265	232	265
UAL 2										284	244	287
UAL 3										317	274	324
UAL 4										377	323	389

NOTE: Different stroke lengths available on request. $L_a = L_c + \text{STROKE}$

For stroke lengths longer than 800 mm it is necessary to increase the guided length between push rod and outer tube to avoid axial backlash. Dimensions **S2**, **T** and **Q2** shall be considered increased by 200 mm for stroke lengths up to 1500 mm.

For stroke lengths longer than 1500 mm, please, contact SERVOMECH.

	A	B	B1	C	CH	∅ D1	∅ D2	E	G	H1	H2	H3	I	L1	L2
UAL 1	85	52	110	114	22	25	36	189	15	58	75	55	90	167	193
UAL 2	94	60	115	127	27	30	45	217	17	64	90	62	104	193	229
UAL 3	106	71	124	135	30	35	55	247	20	68	90	75	121	215	304
UAL 4	120	77	141	161	36	40	60	293	24	81	95	90	138	235	340

	R1	∅ X	a	b	c	e	∅ g	h	∅ i	l	∅ o	r1	s	t
UAL 1	17	110	54	28	73	46	10	36	M10x1.5	17	9	18	10	4
UAL 2	20	123	62	32	80	50	12	40	M12x1.75	18	9	20	11	8
UAL 3	20	150	72	38	90	58	14	45	M14x2	24	9	22	12	8
UAL 4	22	170	85	55	110	81	20	58	M20x1.5	27	11	29	15	15

4

FRONT ATTACHMENT Dimensions

	∅ a	∅ b	∅ c	∅ D1	∅ d2	g	∅ g1	k	p	p1
UAL 1	55	40	5.5	25	28	10	10	20	31	45
UAL 2	60	45	6.5	30	32	12	12	24	36	52
UAL 3	65	50	6.5	35	36	14	14	27	36	54
UAL 4	80	60	8.5	40	50	20	20	40	53	78

	q	r	s2	s3	t1	∅ t1	u	w	w1	w2	w3
UAL 1	8	27	14	11	26	14	15	49	61	20	12
UAL 2	9	28	16	12	32	16	18	56	70	24	14
UAL 3	9	32	19	14	36	18	21	65	81	28	16
UAL 4	10	42	25	18	42	25	27	90	115	40	25

MAGNETIC STROKE LIMIT SWITCHES FCM Technical features and dimensions

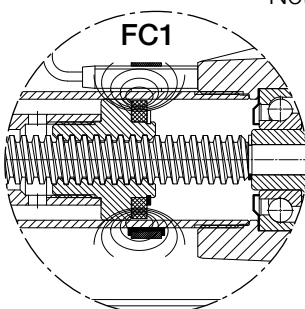

Note: - Additional extra magnetic REED SWITCHES are available for intermediate positions.

- The minimum distance between the REED SWITCHES must be of at least 10 mm.

- REED SWITCH Normally Closed (NC) R = 39 mm

- REED SWITCH Change-over (NC+NO) R = 39 mm

- REED SWITCH Normally Open (NO) R = 29 mm

Linear actuators UAL Series

ACME SCREW LINEAR ACTUATORS UAL Series, size 1 – 2 – 3 – 4
DC MOTOR – with Magnetic Stroke Limit Switches FCM

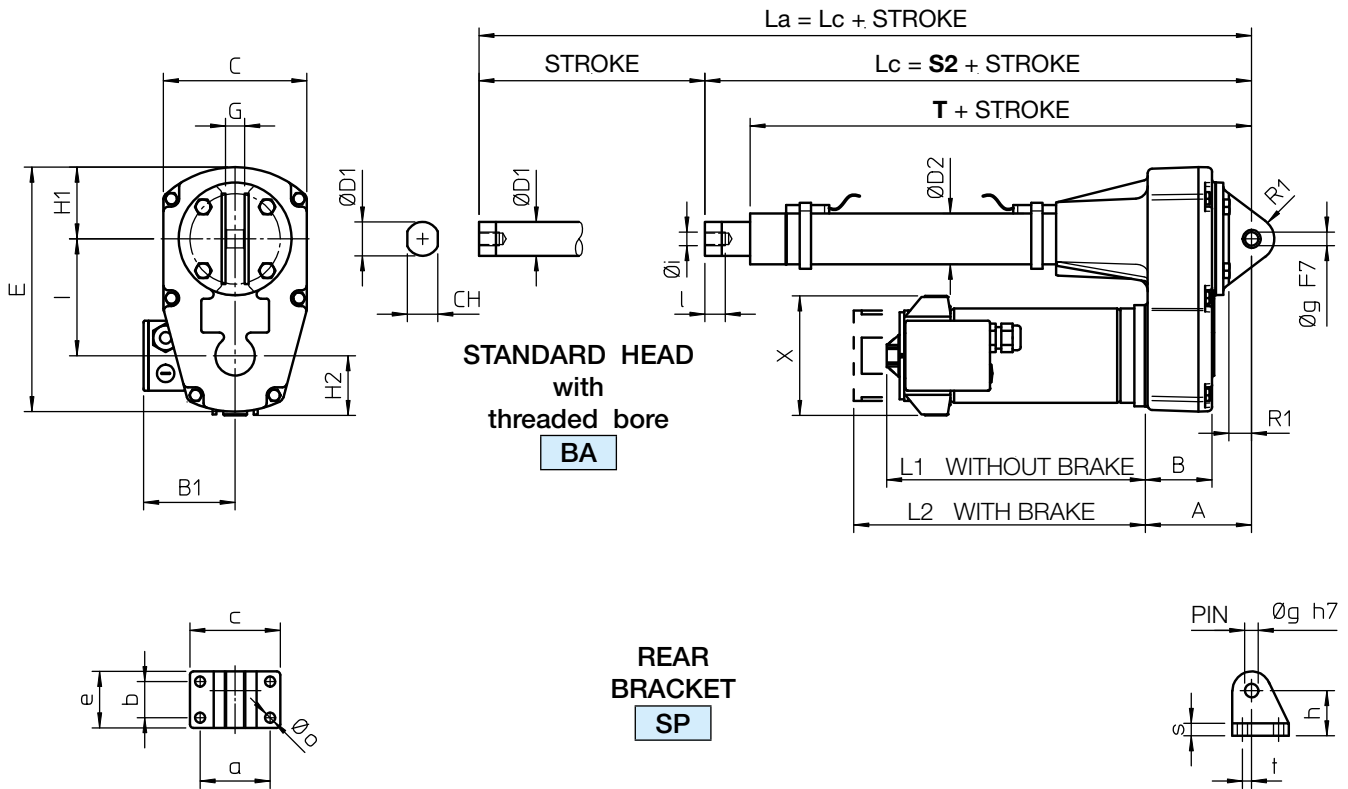

L_c - RETRACTED ACTUATOR length
 L_a - EXTENDED ACTUATOR length

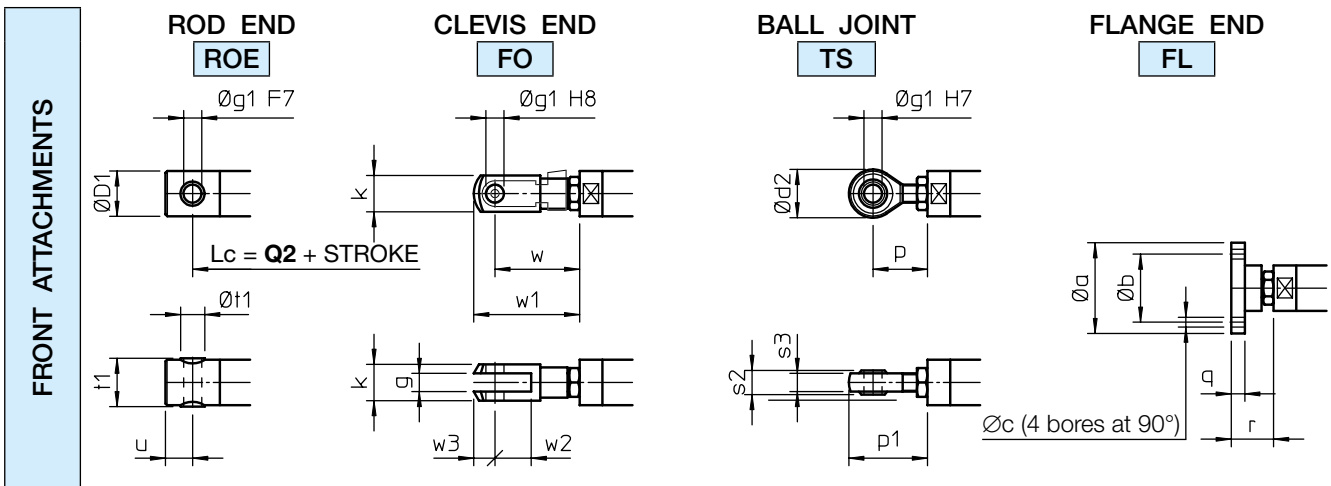

MAGNETIC STROKE LIMIT SWITCHES FCM Dimensions

	L	
	REED CONTACT NC or (NC+NO)	NO
UAL 1	42	47
UAL 2	51	56
UAL 3	59	64
UAL 4	69	74

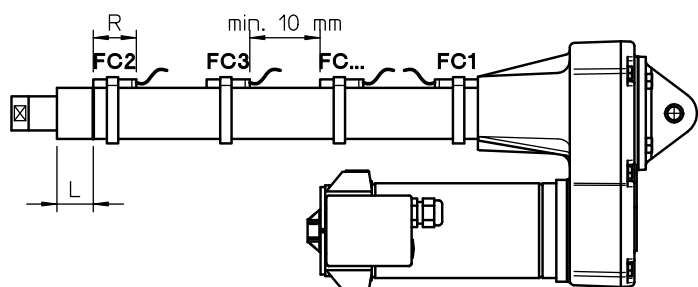

Linear actuators UAL Series

ACME SCREW LINEAR ACTUATORS UAL Series, size 1 – 2 – 3 – 4
DC MOTOR – with Magnetic Stroke Limit Switches FCM
STANDARD STROKE LENGTHS

	STROKE CODE	C100	C200	C300	C400	C500	C600	C700	C800	S2	T	Q2
UAL 1	STROKE [mm]	100	200	300	400	500	600	700	800	265	232	265
UAL 2										284	244	287
UAL 3										317	274	324
UAL 4										377	323	389

NOTE: Different stroke lengths available on request. $L_a = L_c + \text{STROKE}$

For stroke lengths longer than 800 mm it is necessary to increase the guided length between push rod and outer tube to avoid axial backlash. Dimensions **S2**, **T** and **Q2** shall be considered increased by 200 mm for stroke lengths up to 1500 mm.

For stroke lengths longer than 1500 mm, please, contact SERVOMECH.

	A	B	B1	C	CH	∅ D1	∅ D2	E	G	H1	H2	H3	I	L1	L2
UAL 1	85	52	110	114	22	25	36	189	15	58	75	55	90	167	193
UAL 2	94	60	115	127	27	30	45	217	17	64	90	62	104	193	229
UAL 3	106	71	124	135	30	35	55	247	20	68	90	75	121	215	304
UAL 4	120	77	141	161	36	40	60	293	24	81	95	90	138	235	340

	R1	∅ X	a	b	c	e	∅ g	h	∅ i	l	∅ o	r1	s	t
UAL 1	17	110	54	28	73	46	10	36	M10×1.5	17	9	18	10	4
UAL 2	20	123	62	32	80	50	12	40	M12×1.75	18	9	20	11	8
UAL 3	20	150	72	38	90	58	14	45	M14×2	24	9	22	12	8
UAL 4	22	170	85	55	110	81	20	58	M20×1.5	27	11	29	15	15

4

FRONT ATTACHMENT Dimensions

	∅ a	∅ b	∅ c	∅ D1	∅ d2	g	∅ g1	k	p	p1
UAL 1	55	40	5.5	25	28	10	10	20	31	45
UAL 2	60	45	6.5	30	32	12	12	24	36	52
UAL 3	65	50	6.5	35	36	14	14	27	36	54
UAL 4	80	60	8.5	40	50	20	20	40	53	78

	q	r	s2	s3	t1	∅ t1	u	w	w1	w2	w3
UAL 1	8	27	14	11	26	14	15	49	61	20	12
UAL 2	9	28	16	12	32	16	18	56	70	24	14
UAL 3	9	32	19	14	36	18	21	65	81	28	16
UAL 4	10	42	25	18	42	25	27	90	115	40	25

MAGNETIC STROKE LIMIT SWITCHES FCM Technical features and dimensions

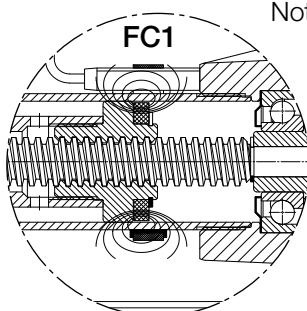

- Note: - Additional extra magnetic REED SWITCHES are available for intermediate positions.
 - The minimum distance between the REED SWITCHES must be of at least 10 mm.
- | | | | |
|---------------|-----------------|---------|-----------|
| - REED SWITCH | Normally Closed | (NC) | R = 39 mm |
| - REED SWITCH | Change-over | (NC+NO) | R = 39 mm |
| - REED SWITCH | Normally Open | (NO) | R = 29 mm |

Linear actuators UBA Series and UAL Series

4.5 OPTIONS AND ACCESSORIES

ELECTRIC MOTOR TERMINAL BOX POSITION

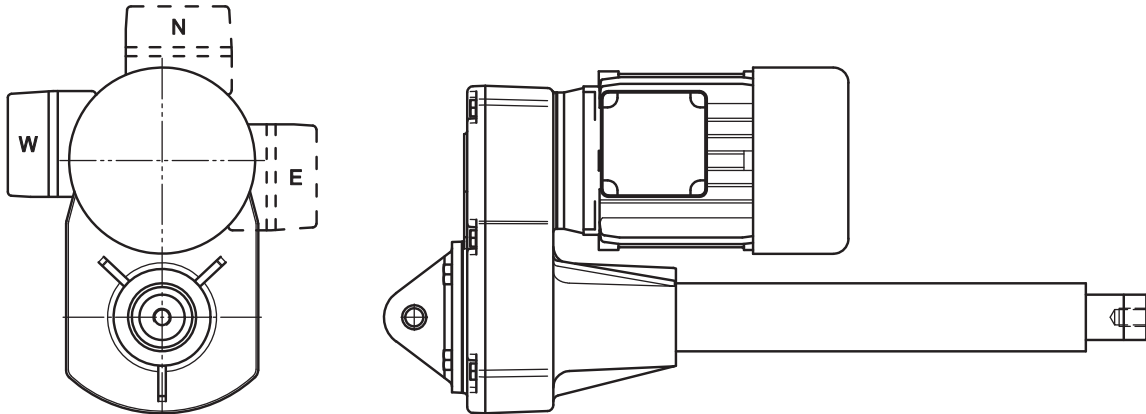

STANDARD side: W
ON REQUEST side E ; N

POSITION OF FRONT AND REAR ACTUATOR ATTACHMENT

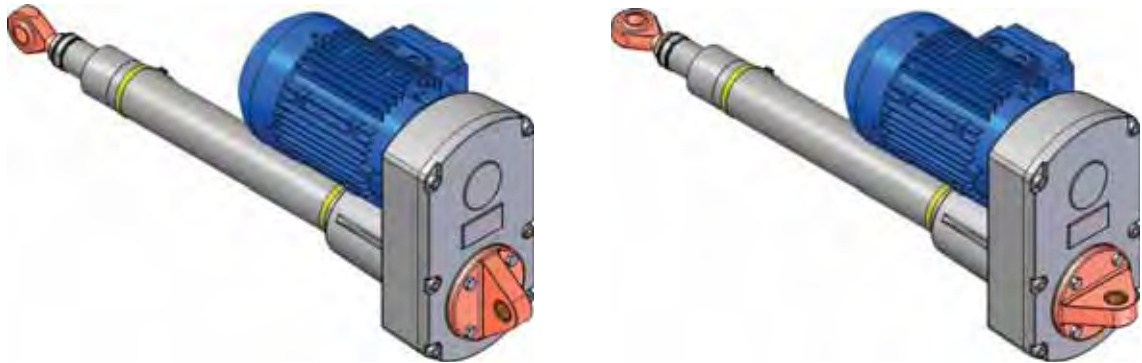

STANDARD

ON REQUEST: turned at 90°
Code: RPT 90°

INTERMEDIATE FLANGE Code FI

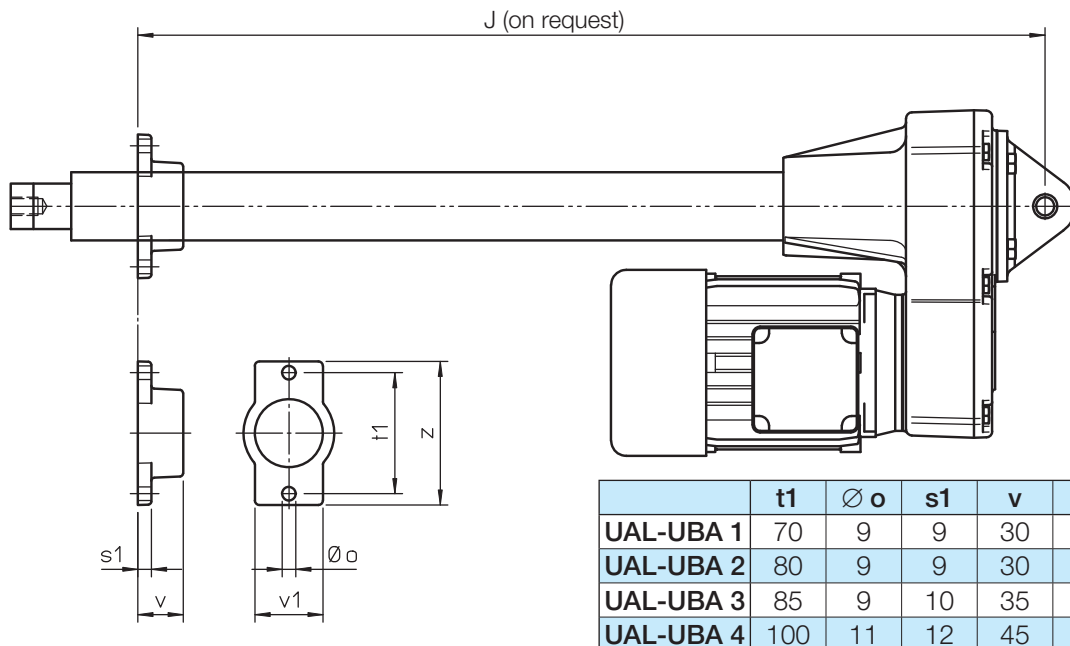

NOTE: the intermediate flange FI can be used as sustainer only and not to support the axial load!

Linear actuators UBA Series and UAL Series

4.5 ACCESSORIES

MAGNETIC STROKE END SWITCHES Code FCM

The MAGNETIC STROKE END SWITCHES FCM allow to limit the actuator stroke length avoiding to reach the extreme positions (mechanical stop) and preventing damage. Using more switches it is also possible to set intermediate positions along the actuator stroke length.

These reeds can be used to stop the actuator or simply to signal its position during the linear motion.

A magnetic ring on the actuator push road creates a toroidal magnetic field of 100 Gauß.

The stroke end switches must be fixed on the push rod and are activated by the toroidal magnetic field independently of their angular position.

The outer tubes are made in non-magnetic material, such as anodized aluminium or stainless steel, thus allowing the external transmission of the magnetic field and therefore activation of the reeds switches.

The standard construction of actuators with FCM includes the outer tube in anodized aluminium; tubes in stainless steel are available on request.

The stroke end switches must be fixed with clamps in non-magnetic material and, to be activated, they must be mounted with the side with the code number upwards (the sensor code number shall be visible).

WARNING: Max. performances stated in this catalogue and/or technical data sheets supplied with the actuator must not be exceeded, in order to avoid damages and malfunction!
The magnetic reed switches can work only if connected to a control circuit to activate electric relay. They shall not be connected in series between the power supply and the electric motor.

- RETRACTED ACTUATOR (Lc) position: sensor FC 1
- EXTENDED ACTUATOR (La) position: sensor FC 2

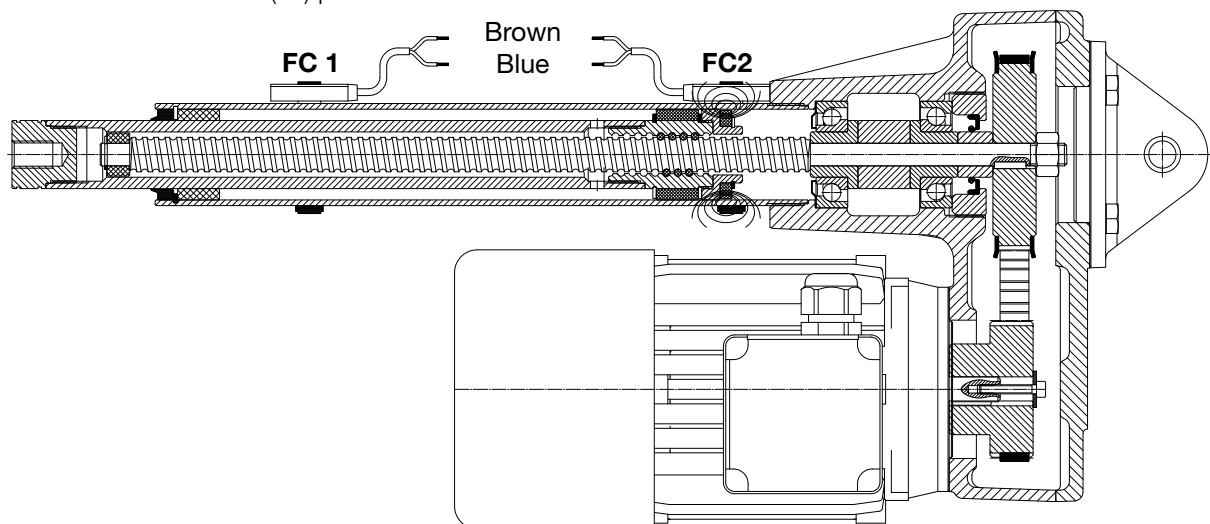

The toroidal magnetic field created by the internal magnetic ring has an arch-like form. When using more contact reeds for intermediate positions, it shall be considered that the same reed switch can give the signal in 2 different positions, depending on the actuator motion which can be retracting or extending. To know the difference between these 2 positions please contact SERVOMECH.

The position of the reed switches can be adjusted by changing the fixing clamp position on the outer tube.

The MAGNETIC STROKE END SWITCHES FCM are available for actuators of both UAL and UBA Series, for size 1 ... 4.

NOTE: The FCM is not available if the actuator is equipped with ANTI-TURN device AR.

Linear actuators UBA Series and UAL Series

4.5 ACCESSORIES

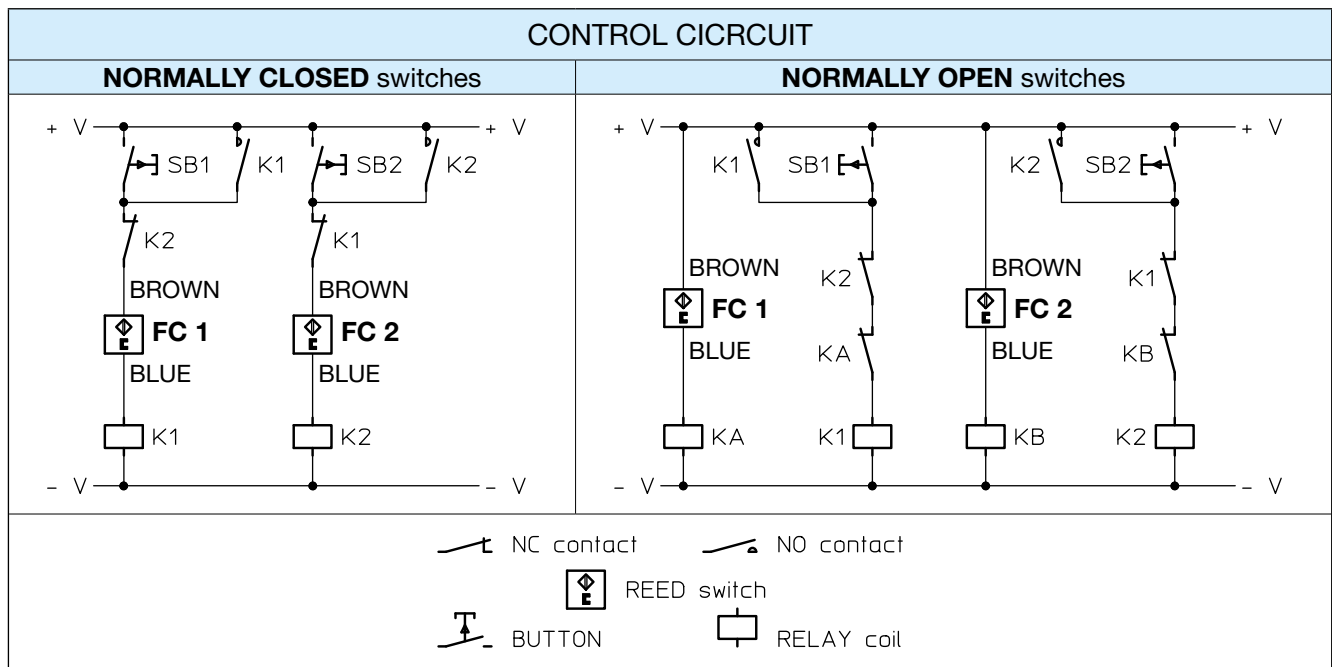

The extreme reed switches positions are:

- RETRACTED ACTUATOR (Lc) position: the reed switch fixed on the tube up to the actuator housing
- EXTENDED ACTUATOR (La) position: the reed switch must exceed the limit marked on the outer tube.

This limit position is given on the tables stating the dimensions for standard stroke lengths up to 800 mm. For special stroke lengths longer than 800 mm, the limit position is the one marked on the tube, otherwise please contact SERVOMECH (also in this case it is marked on the actuator).

ELECTRIC FEATURES		
Voltage	(3 ... 130) V DC	(3 ... 130) V AC
Max. commutable power	20 W	20 VA
Max. commutable current	300 mA (resistive load)	
Max. inductive load	3 W (simple coil)	

The reed switches are equipped with a multicore cable 2 × 0.25 mm², standard length 2 m.

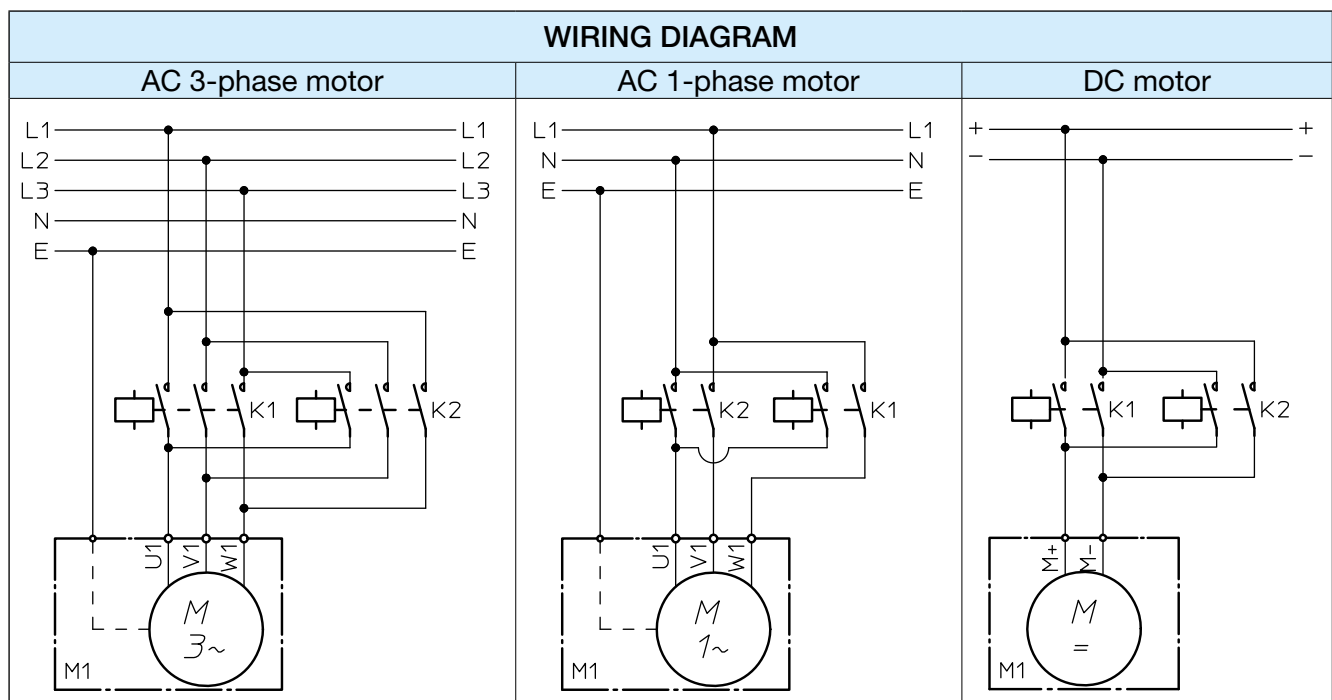

Linear actuators UBA Series and UAL Series

4.5 ACCESSORIES

INDUCTIVE PROXIMITY STROKE END SWITCHES Code FCP

The INDUCTIVE PROXIMITY STROKE END SWITCHES FCP allow the actuator to stop before reaching the internal mechanical stop avoiding damage. They can be also used to fix intermediate positions along the actuator stroke length.

The INDUCTIVE PROXIMITY STROKE END SWITCHES are fixed directly on the actuator outer tube in the required position. Their position is not adjustable. Standard proximity switches are normally closed.

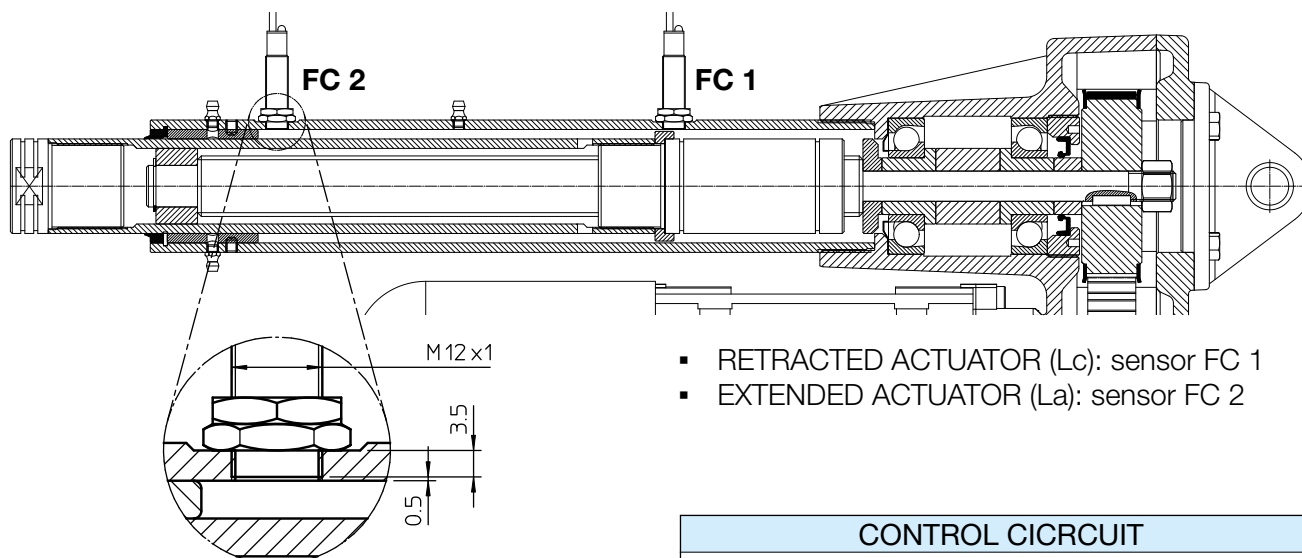

- RETRACTED ACTUATOR (Lc): sensor FC 1
- EXTENDED ACTUATOR (La): sensor FC 2

ELECTRIC FEATURES	
Voltage	(10 ... 30) V DC
Max. output current	200 mA
Voltage drop (activated switch)	< 3 V (at 200 mA)

The switches are equipped with a multicore cable 3 × 0.2 mm², standard length 2 m.

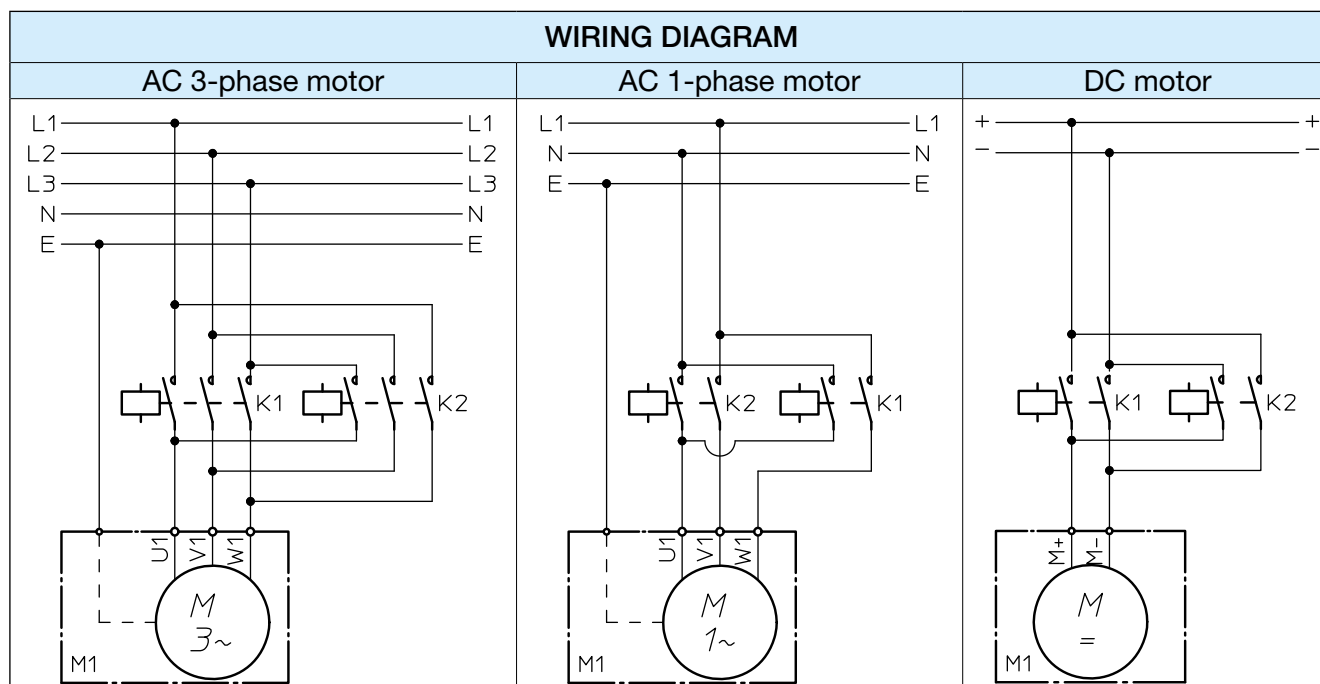
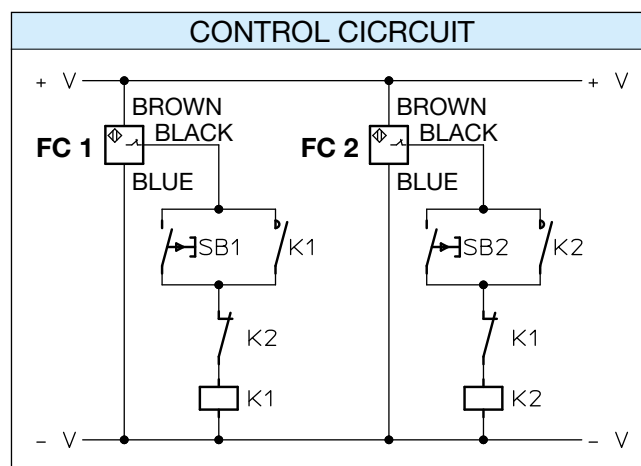
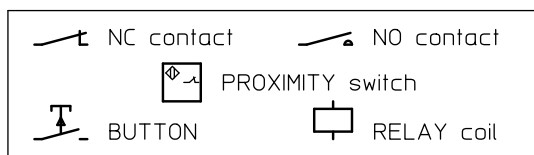

Linear actuators UBA Series and UAL Series

4.5 ACCESSORIES

ANTI-TURN device Code AR

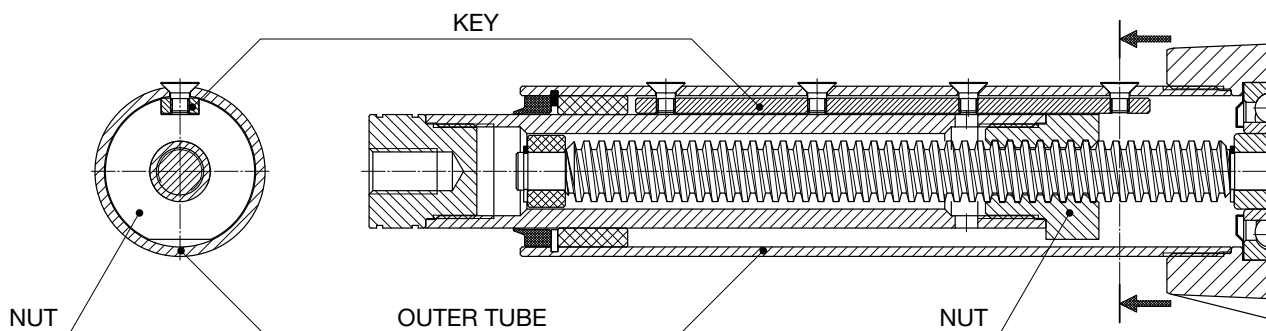

To achieve a linear motion it is necessary to prevent the rotary movement of the nut and of the push rod fixed to it. In many applications it is the external structure itself that, being connected to the push rod, prevents the rotation and allows the linear motion.

In some cases the load applied on the push rod cannot be guided and therefore the rotation cannot be avoided. In such cases it is necessary to use actuators with an internal anti-turn device. The ANTI-TURN device allows the linear motion without any external reaction on the push rod. It can be supplied upon request.

The anti-turn device shown in the above picture consists in a steel key fixed and aligned along the outer tube. The bronze nut, provided with a suitable keyway, slides on this key, making translate the push rod.

The ANTI-TURN device AR is available for linear actuators UAL 2, UAL 3, UAL 4 **without MAGNETIC STROKE END SWITCHES FCM** and UAL 5. **It is not available** for actuators UAL 1 and for all ball screw linear actuators (UBA Series).

SAFETY NUT Code MS

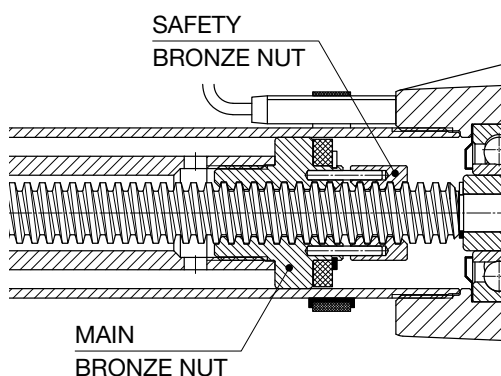

The SAFETY NUT is an auxiliary bronze nut connected by 2 pins to the main bronze nut. The distance between the two nuts in a new actuator is equal to a half of the thread pitch. If the main nut wears up to a half of the thread pitch or crashes, the SAFETY NUT supports the load avoiding its fall.

The SAFETY NUT is a one-direction device. Its position with respect to the main nut depends on the load direction. The SAFETY NUT is available for actuators working with push load. For applications with pull load a special design is available (contact SERVOMECH).

The SAFETY NUT MS is available for acme screw actuators UAL 2, UAL 3, UAL 4 and UAL 5.

4

Linear actuators UBA Series and UAL Series

4.5 ACCESSORIES

PROTECTIVE BELLOWS Code B

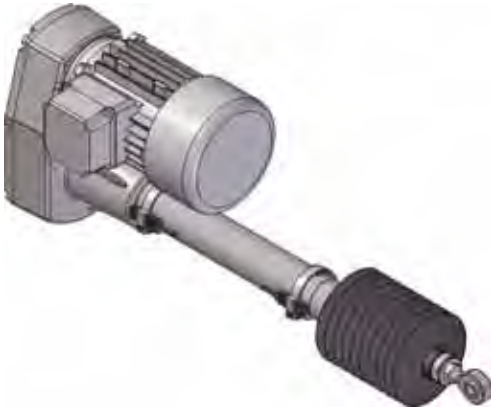

When the actuators are used in particular environment conditions with contaminant agents that can damage the seal scraper between the outer tube and the push rod, BELLOWS protection can be useful.

Bellows made of special materials for hard environments are available upon request.

ROTARY ENCODER

For the positioning control of all linear actuators ATL Series and BSA Series (all sizes), an incremental rotary encoders can be supplied, fixed to the housing, the side opposite to the motor, and connected to the motor shaft through an auxiliary shaft.

On request, the linear actuator can be equipped with an absolute rotary encoder.

ROTARY ENCODER Code EH 53

Optical encoder, incremental, bi-directional

Resolution: 100 or 500 pulses per revolution

Output: PUSH-PULL

2 channels (phase difference 90°)
channel ZERO

Input voltage: (8 ... 24) Vcc

No-load current: 100 mA

Max. commutable current: 50 mA

Cable length: 0.5 m

Protection: IP 54

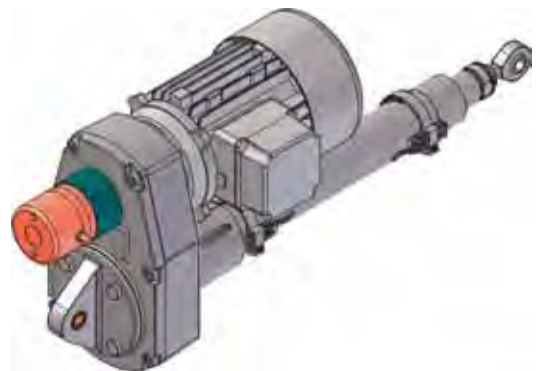

(On request, in case of linear actuators with DC motor, the motor can be supplied with a tacho-generator mounted on the opposite side of the motor shaft.)

4.6 SPECIAL DESIGNS

According to specific application requirements, special designs can be carried out on standard actuators.

Some possible options are for example:

- push rod in stainless steel AISI 304
- outer tube in stainless steel AISI 304
- lubricants for high or low ambient temperature
- lubricants suitable for food industry
- seals in VITON or silicone
- wiper seal on push rod with second lip in brass (ice scrapers)

Thanks to the long experience and know-how, SERVOMECH is able to support customers in selecting the right actuator version and accessories suitable for specific environment and installation conditions.

Linear actuators UBA Series and UAL Series

4.6 ORDERING CODE

UBA	4	RN2	C300	FO	—	FCM
1	2	3	4	5	6	7

SP encoder ...	
	8

AC 3-phase brake-motor 0.75 kW 4-pole 230/400 V 50 Hz IP 55 Ins. F	W
9.A	9.B

1	Actuator series UBA or UAL	
2	Actuator size 1, 2, 3, 4, 5	pages 128 ... 129
3	Ratio RV1, RN1, RL1 RV2, RN2, RL2	pages 128 ... 129
4	Stroke code C100, C200, C300, C400, C500, C600, C700, C800 (special stroke available on request)	
5	Front attachment BA - standard head with threaded bore ROE - rod end FO - clevis end TS - ball joint FL - flange end TF - hinged head	pages 136 ... 145
6	Position of front and rear actuator attachment STANDARD (without code) or RPT 90°	page 146
7	Stroke end switches FCM-NC - magnetic reed switches, normally closed FCM-NO - magnetic reed switches normally open FCP - inductive proximity switches	pages 147 ... 148 pages 147 ... 148 page 149
8	Accessories SP - rear bracket FI - intermediate support flange AR - anti-turn device MS - safety nut for push load B - bellows encoder - EH 53 or according to required specifications	pages 136 ... 145 page 146 page 150 page 150 page 151 page 151
9.A	Motor data	pages 200 ... 201
9.B	Motor terminal box position	page 146
10	Other specifications example: push rod in stainless steel AISI 303 example: lubricant for low temperature	
11	Filled in SELECTION DATA sheet	page 147
12	Application layout	

APPLICATION: _____

REQUIRED STROKE: _____ mm

REQUIRED LINEAR SPEED: _____ mm/s _____ mm/min _____ m/min TIME TO PERFORM 1 STROKE: _____ s

STATIC LOAD: PULL: _____ N PUSH: _____ N at STROKE _____ mm

DYNAMIC LOAD: PULL: _____ N PUSH: _____ N at STROKE _____ mm

ACTUATOR SUBJECTED TO VIBRATIONS NOT SUBJECTED TO VIBRATIONS

OPERATING: _____ cycle / hour _____ working hours / day Notes: _____

REQUIRED LIFETIME: _____ cycle _____ hours _____ calendar days Notes: _____

ENVIRONMENT: TEMPERATURE _____ °C DUST HUMIDITY _____ % AGGRESSIVE AGENT _____

Ball screw actuators **UBA Series** Acme screw actuators **UAL Series**

Size: 1 2 3 4 5

Ratio: RV2 RV1 RN2 RN1 RL2 RL1

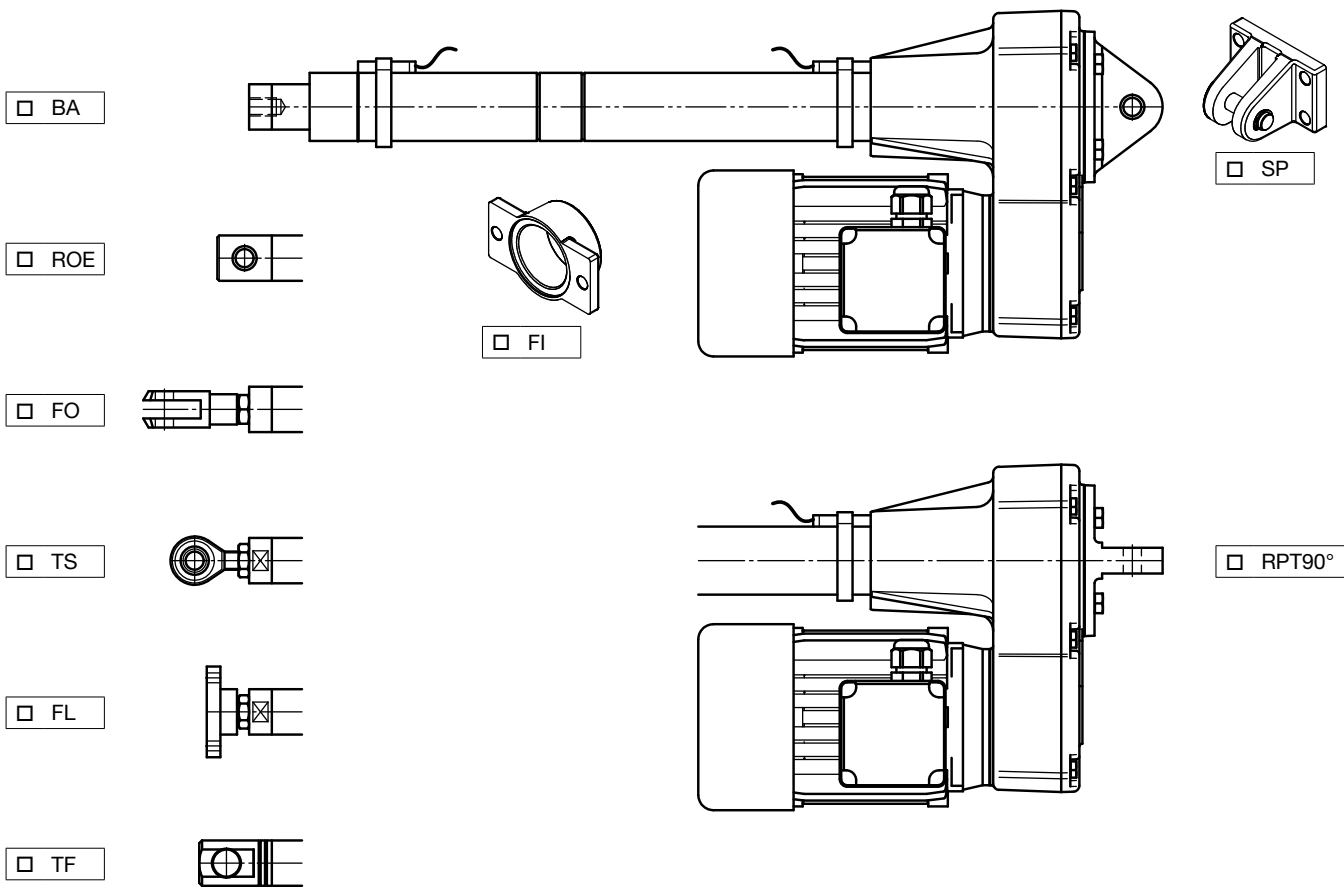

ELECTRIC MOTOR AC 3-phase AC 1-phase DC 24 V or 12 V WITHOUT BRAKE WITH BRAKE

STROKE END SWITCHES ELECTRIC FCE MAGNETIC FCM PROXIMITY FCP

ROTARY ENCODER

ANTI-TURN DEVICE AR SAFETY NUT MS

BELLOWS PUSH ROD IN STAINLESS STEEL OUTER TUBE IN STAINLESS STEEL

OTHER: _____

Ball screw actuators **UBA Series**

Acme screw actuators **UAL Series**

PRODUCT: _____

Product serial number: _____ ; q.ty: _____

STANDARD HEAD

BA

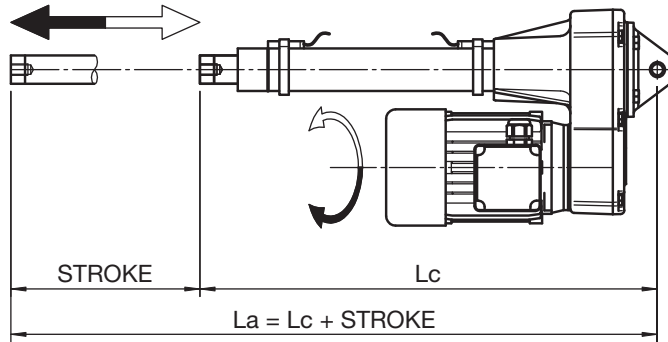

ELECTRIC MOTOR

- AC 3-phase
- AC 1-phase
- DC

- WITHOUT brake
- WITH brake
 - internally powered
 - separately powered

CLEVIS END

FO

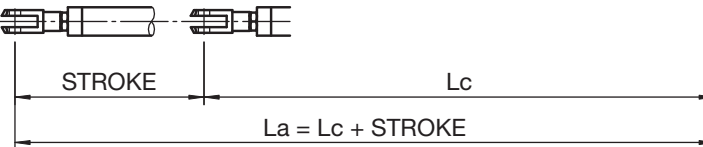

BALL JOINT

TS

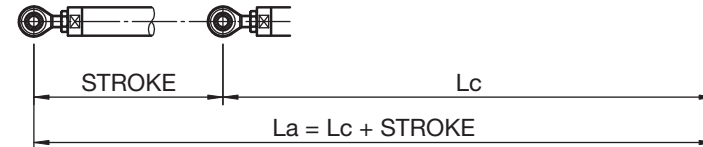

FLANGE END

FL

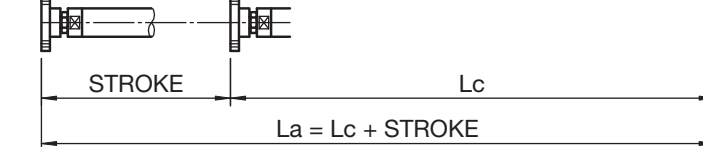

ROD END

ROE

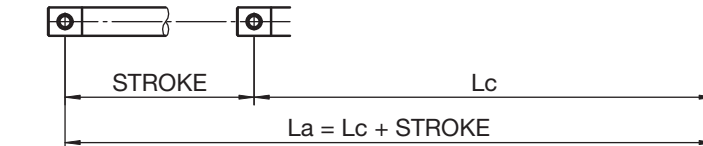

HINGED HEAD

TF

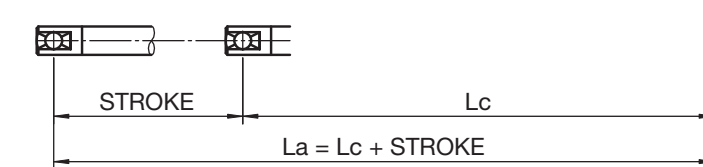

Servomech. QMS

PASSED

Date: _____

Signature: _____

LINEAR ACTUATOR LENGTH (ref. to BA ROE TF FL)

WORKING RANGE

INTERNAL MECHANICAL STOP LIMIT

RETRACTED ACTUATOR length:	Lc = _____ mm	MIN. actuator length:	_____ mm
EXTENDED ACTUATOR length:	La = _____ mm	MAX. actuator length:	_____ mm
STROKE (La - Lc):	C = _____ mm		

MAGNETIC STROKE END SWITCHES **FCM** □

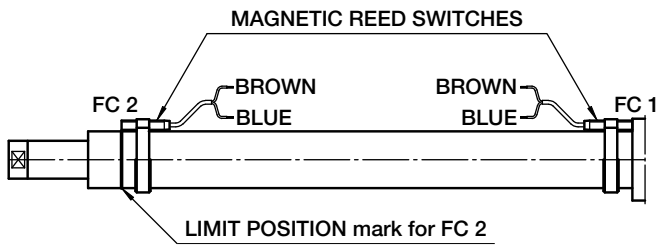

The MAGNETIC STROKE END SWITCHES **FCM** has reed switches FC 1 and FC 2. The rated electric values are indicated on the reed switch. The RETRACTED ACTUATOR position is adjusted and controlled by FC 1. The EXTENDED ACTUATOR position is adjusted and controlled by FC 2. Reed switch wires are BROWN and BLUE (and the third, BLACK, for change-over contact). For DC supply: connect the BROWN wire to ⊕.

PROXIMITY STROKE END SWITCHES **FCP** □

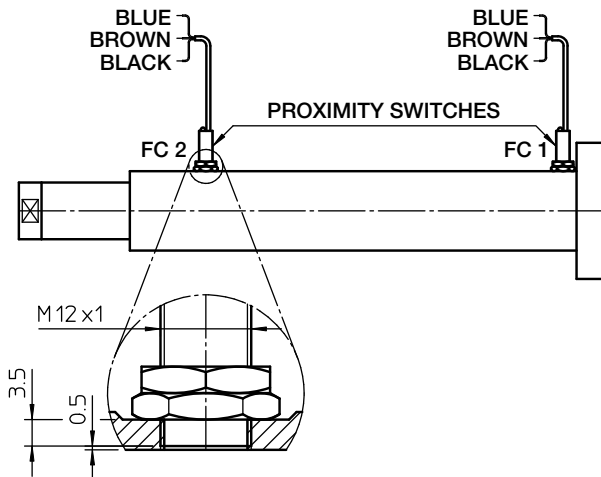

The PROXIMITY STROKE END SWITCHES **FCP** has proximity sensors FC 1 and FC 2.

- type: inductive, PNP
- contact: **normally CLOSED**
- supply voltage: (10 ... 30) V DC
- max. output current: 200 mA
- max. voltage drop (activated sensor): < 3 V (ref. 200 mA)

FC 1 - sensor for RETRACTED ACTUATOR position
FC 2 - sensor for EXTENDED ACTUATOR position

SINGLE SENSOR WIRING:



WARNING!

1. The values **Lc** (RETRACTED ACTUATOR length), **La** (EXTENDED ACTUATOR length) and **C** (STROKE) are the extreme limit values.
2. **BEFORE** using the linear actuator:
 - verify the input shaft rotating direction and the push rod running direction;
 - check the stroke end switches position: they must not exceed the extreme limit positions;
 - make sure that the motor and the limit switches are correctly connected and that the right voltage is used.
3. Linear actuators equipped with brake motor:
 - the brake is **NORMALLY CLOSED** (NEGATIVE action). When the power supply is switched off, the brake is engaged. The brake opens only when power is supplied;
 - if the brake is wired directly to the connecting pins of the terminal box, it does not require any power supply;
 - if the brake is wired separately, make sure that the correct voltage is used;
 - if the brake is equipped with hand release device, make sure that the brake is engaged before starting the linear actuator.
4. **Alignment check:** the load must be in line with the actuator. No off-set or radial loads are allowed.

NOTE: _____

WORMGEAR LUBRICANT: _____

SCREW – NUT LUBRICANT: _____